

# Equipment Maintenance

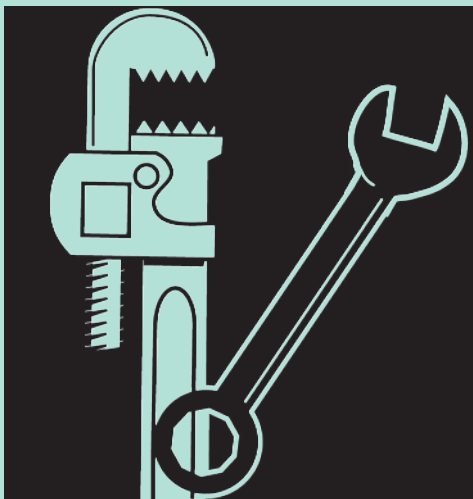

## The New Mexico Irrigator's Pocket Guide



NATIONAL CENTER  
FOR APPROPRIATE  
TECHNOLOGY



**ATTRA**  
SUSTAINABLE AGRICULTURE

Copyright © 2023 National Center for Appropriate Technology

3040 Continental Drive

P.O. Box 3838

Butte, MT 59702-3838

1-800-ASK-NCAT

NCAT.ORG

All rights reserved. No part of this publication may be copied or reproduced in any form, by means of graphic, electronic, mechanical, photocopying, recording, or other methods, without written permission from the National Center for Appropriate Technology.



Printed on Forest Stewardship Council certified paper, using non-toxic and biodegradable vegetable-based inks.

*While every precaution has been taken in the preparation of this document, neither NCAT, nor the authors, nor the funders assume any liability for any loss or damage caused or alleged to be caused, directly or indirectly, to any person or entity by the information or instructions contained in this book. Reference to any specific commercial product, process, company, individual, or service does not imply endorsement, recommendation, or favoring.*

*This publication is based upon work supported by the Natural Resources Conservation Service, U.S. Department of Agriculture, under number NR203A750001C025. Any opinions, findings, conclusions, or recommendations expressed in this publication are those of the authors and do not necessarily reflect the views of the U.S. Department of Agriculture. USDA is an equal opportunity provider and employer.*



## Publication Staff

Project Leader . . . . .	Mike Morris
Writers . . . . .	Mike Morris Vicki Lynne Nancy Matheson Barbara Bellows
Layout and Illustrations. . . . .	Amy Smith

## Preface

Over the two decades since it first appeared in 2003, this take-to-the-field guidebook has evolved through over a dozen editions with comments and advice from irrigation experts around the country. Besides the usual updates and corrections, this new version puts greater emphasis on the importance of soil health. Recent advances in soil science have taught us a great deal about how biologically dead or depleted soils can be brought back to life. When soils get healthier, they catch and hold more water—sometimes a lot more. Taking care of soil health should therefore be a high priority for all irrigators.

We appreciate all who have helped create and update this book over the years. We'd especially like to thank:

Greg Ames, David Amman, Ann Baldwin, Jim Bauder, David Bausch, Jim Beck, Linzy Browning, John Busch, Joel Cahoon, Greg Clouse, Lynn Cornia, John Dalton, John Doubek, David Fischer, Allen Gehring, Tim Grove, Joe Hamm, Mike Hansen, Jim Headlee, Stephen Henry, John Hester, Larry Hoffman, Carolyn Jones, Kristin Keith, Patricia Kelley, Larry King, Rob Krause, Ron Lee, Mark Lere, Barbara Lien, Doug Mawhinney, Brady McElroy, Mike McLane, Danielle Miska, Justin Morris, David Nelson, Leigh Nelson, Merlin Nelson, Troy Peters, Clare Prestwich, Stephen Rogers, Bruce Sandoval, Dave Scott, Marty Soffran, David Spengler, Alan Stahl, Mark Twyeffort, Daniel Vichorek, Gerald Westesen, Darol Wilson, Jesse Wilson, and Brian Wright.



Since 1976, the private, nonprofit **National Center for Appropriate Technology (NCAT)** has been a trusted, practical connector: promoting technologies that enable people to protect natural resources and live better lives. NCAT offers technical assistance, publications, videos, conferences, and websites. Visit [NCAT.ORG](http://NCAT.ORG).



NCAT's **ATTRA Program** offers no-cost assistance to farmers, ranchers, and other agriculture professionals on sustainable production, marketing, and climate resilience. Visit [ATTRA.NCAT.ORG](http://ATTRA.NCAT.ORG).



NCAT's **Soil for Water Program** is a peer-to-peer learning community, resource, and story collection devoted to catching and storing more water in soil. All are welcome. Visit [SOILFORWATER.ORG](http://SOILFORWATER.ORG)

*NCAT is committed to providing equal opportunities and access to all of its programs and activities, including recruitment and hiring. NCAT prohibits discrimination on the basis of color, race, religion, sex, national origin, age, disability, sexual preference, marital, or veteran status.*

# Table of Contents

<b>Introduction</b> . . . . .	<b>1</b>
<b>1. Recommended Installations</b> . . . . .	<b>3</b>
Centrifugal Pumping Plant with Electric Motor . . . . .	3
Turbine Pump Installation . . . . .	6
Control Panel for Electric Motors. . . . .	8
<b>2. Pumping Plant Maintenance</b> . . . . .	<b>9</b>
Electric Motors . . . . .	9
Control Panel. . . . .	12
Engines . . . . .	14
Centrifugal Pumps . . . . .	18
Vertical Turbine Pumps . . . . .	24
Troubleshooting . . . . .	29
Pumping Plant Maintenance Form . . . . .	32
<b>3. Distribution System Maintenance</b> . . . . .	<b>33</b>
Sprinkler Systems . . . . .	33
Surface Systems . . . . .	42
Microirrigation Systems. . . . .	42
Sprinkler System Maintenance Form . . . . .	46
<b>4. Saving Energy</b> . . . . .	<b>47</b>
Electrical Use and the Charges on Your Power Bill . . . . .	47
Common Causes of Wasted Energy. . . . .	49
Hardware Improvements . . . . .	51

## Figures

1. Ideal and Poor Installations . . . . .	3
2. Recommended Pump Installation . . . . .	4
3. Deep Well Turbine Pump . . . . .	7
4. Centrifugal Pump and Electric Motor . . . . .	19
5. Impeller Eye and Wear Ring . . . . .	20
6. Oil-Lubricated Turbine Pump . . . . .	26
7. Sprinkler Head. . . . .	34

## **Handy Conversions and Formulas**

Volume Conversions . . . . .	.58
Weight Conversions . . . . .	.58
Length Conversions . . . . .	.59
Area Conversions and Formulas . . . . .	.59
Temperature Conversions . . . . .	.59
Power Conversions . . . . .	.60
Electrical Formulas . . . . .	.60
Pressure Conversions . . . . .	.61
Water Velocity Formula . . . . .	.65
Other Pumping Plant Formulas . . . . .	.65
A Simple Method to Estimate Pumping Plant Efficiency .	.68

# Introduction

The *Equipment Maintenance* half of this book gives specific instructions for keeping your irrigation system running properly, including:

- Descriptions and diagrams of recommended pumping plant installations.
- Suggestions for improving water and energy efficiency.
- A troubleshooting guide for pumps and motors.
- Dozens of frequently used conversions and formulas (in the center of the book).
- Detailed instructions for equipment maintenance, broken down by how frequently they need to be done.

This concise take-to-the-field guide is by no means intended to be a complete irrigation manual. For example, it does not tell you how to design an irrigation system and says little about maintaining diversion or conveyance structures (such as pipelines or ditches) for getting water to the farm or field. The discussion generally assumes that you already have an irrigation system in place, and the focus is on maintaining the pumping plant and distribution system.



The wrench symbol indicates maintenance tasks.



The exclamation mark indicates safety hazards, potential equipment damage, possible harm to crops, or other situations calling for extra caution.

No one knows more than you do about your fields and irrigation system. So adjust or reject any suggestion in this book if it doesn't fit your situation or doesn't seem to be working. Proceed cautiously and test every recommendation with direct observations in the field.



# 1. Recommended Installations

## Centrifugal Pumping Plant Installation with Electric Motor

The term *pumping plant* refers to the irrigation pump and motor or engine, considered together. If you have an older system, your pumping plant might look like the *Poor* setup in Figure 1 below on the discharge side. It's a false economy to cut costs by installing smaller valves and fittings since you'll have greater friction loss and higher pumping costs. The next time you rebuild your pump, replace fittings so your pumping plant looks like *Ideal*.

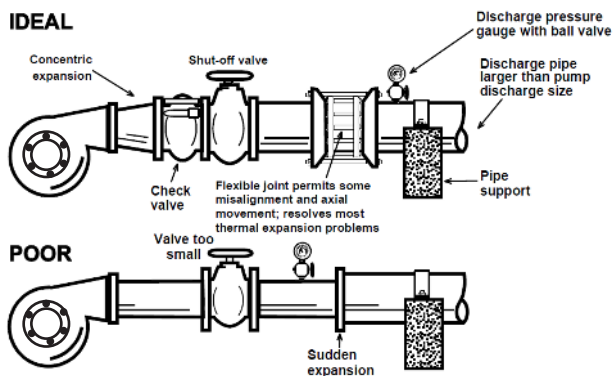
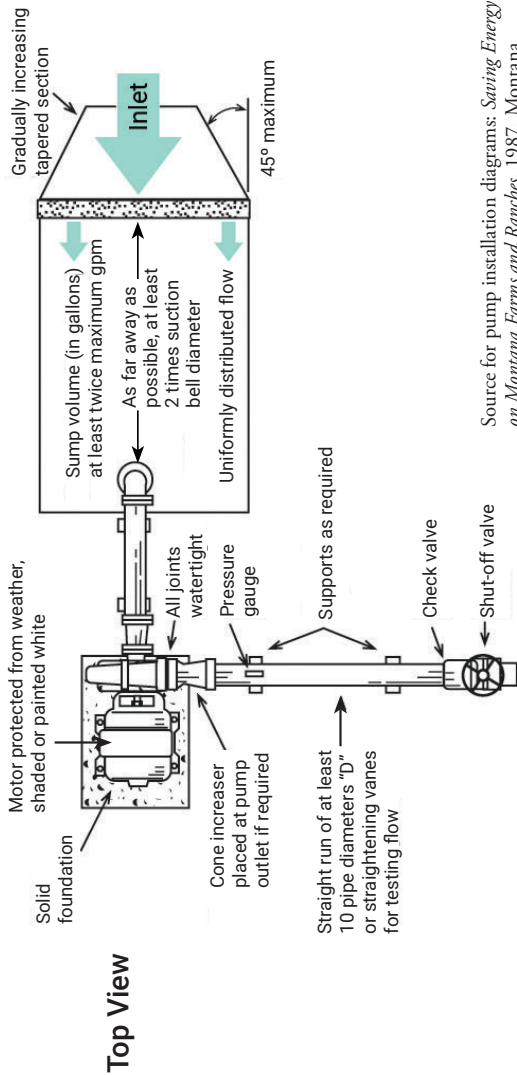

Figure 1. Ideal and Poor Installations

An ideal installation should have:

- A discharge concentric expansion instead of an abrupt change in pipe diameter to minimize head loss, turbulence, and air pockets.
- A discharge valve the same diameter as the mainline.

Figure 2, pages 4-5, shows what your pumping plant should look like when pumping from a surface source such as a river or canal.



Source for pump installation diagrams: *Saving Energy on Montana Farms and Ranches*, 1987. Montana Department of Natural Resource Conservation.

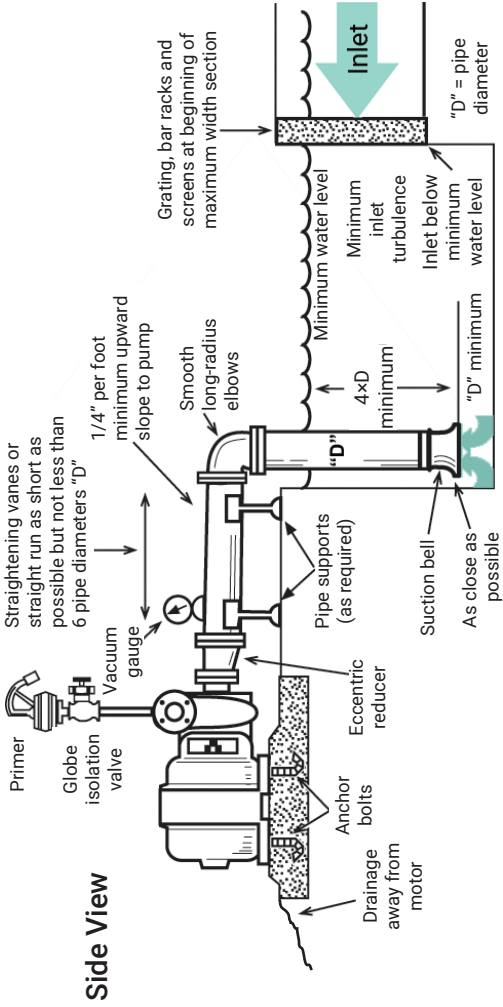

Figure 2. Recommended Pump Installation, Top and Side Views

A well-designed pumping plant should have:

### **Suction Side of Pump**

- A screened sump that keeps trash away.
- Suction line joints that are airtight under a vacuum.
- No high spots where air can collect.
- A suction line water velocity of five feet per second or less. Two to three feet per second is best.
- A suction entrance at least two pipe bell diameters from sump inlet.
- A suction lift (vertical distance from water surface to pump impeller) less than 15 to 20 feet.
- An eccentric reducer to keep air from becoming trapped in the reducer fitting.
- A vacuum gauge to indicate whether the primer is pulling a vacuum or just moving air through the pump.

### **Discharge Side of Pump**

- A valve the same size/diameter as the mainline.
- A non-slam check valve to prevent back spin of the pump when shutting pump off.
- An air relief device when a buried mainline is used.
- A discharge line water velocity of less than seven feet per second. Five feet per second is best.
- An energy-efficient 1800 rpm motor with 15% safety factor.
- A simple shade over the motor.

**! Caution: Figures 1 and 2 show only components directly related to energy efficiency and don't show pressure relief valves, air vents, and other features necessary for safety and performance.**

## **Turbine Pump Installation**

---

Refer to the left half of Figure 3 on the next page for a properly installed turbine pump in a well. Many of these same principles apply to turbine pumps in sumps. A properly designed well should also:

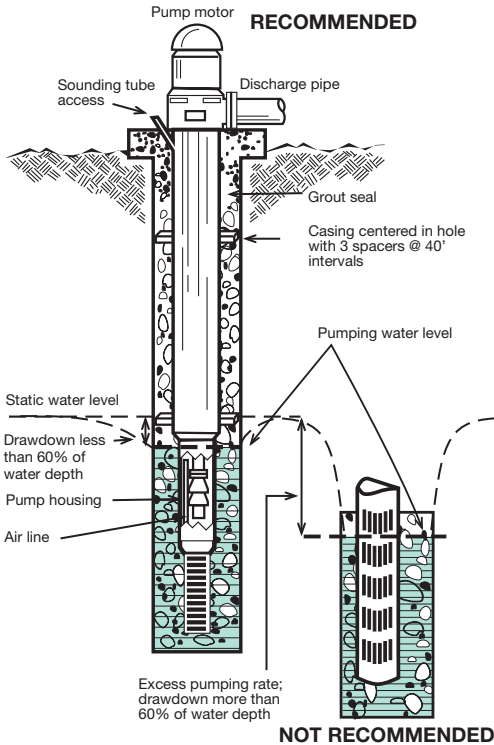

Figure 3. Deep Well Turbine Pump

- Be at least six inches in diameter larger than the outside diameter of the well casing when a gravel pack is required.
- Have horizontal well screen slots that continue below the pumping water level. The openings should hold back at least 85 percent of the surrounding material.

The poorly constructed well in the lower right side of Figure 3 shows a well casing that is not centered in the well. Vertical slotted pipe perforations are also above the minimum water level, creating cascading water.

## About Pressure Gauges

---

A good quality oil- or glycerin-filled pressure gauge on the discharge side of the pump will tell you a lot about your system's condition. If the operational pressure stays close to the original design pressure, the pump is probably in good working order. Pressure changes can indicate clogged suction screens, leaks, pump wear, worn nozzles, or other problems. Use the gauge when filling the mainline to reduce demand and water hammer. Extend the life of your gauge by installing a ball valve on the riser. Keep the valve closed except when referring to the gauge. With a ball valve in place, you also have the option of removing the gauge during the winter.

## Control Panel for Electric Motors

---

The importance of a properly installed control panel cannot be overemphasized for protecting your personal safety and your investment in your pump and motor.

Your control panel should:

- Have a shade over it to cool thermal breakers.
- Be mounted on secure poles or foundation.
- Have any missing knockout plugs and other holes in the starting switch box replaced and screened or puttied against rodents, insects, and dirt.
- Have a small hole (3/16-inch diameter) in the bottom of the panel to allow moisture to drain.
- Have circuit breaker(s) for overload currents.
- Have a lightning arrester.
- Have a surge protector.
- Have a phase failure relay, to protect the motor from phase reversal or failure and from low voltage.
- Have a pressure switch to shut off the motor if pumping pressure drops to undesirable levels.

## 2. Pumping Plant Maintenance

Plan and follow a regular maintenance schedule and see benefits in reduced repair costs, lower operating costs, longer system life, and less stress for you.

**! Caution: The recommendations below are not comprehensive and may not be correct for all systems. Consult your owner's manual and always follow the manufacturer's instructions if they differ from the ones in this guidebook.**

### Electric Motors

---

An electric motor is an air-cooled piece of equipment and needs all the ventilation it can get. Excessive heat is the main cause of reduced motor life, and motors also like to be dry. Keep motor windings dry by keeping pump packing in good condition. Even if windings are protected from moisture, minerals in the water can attach to them, causing early failure.

Regular maintenance is especially critical for 3600 rpm motors and pumps. Motors that operate at 3600 rpm experience twice as much wear as motors operating at 1800 rpm.

#### *General*

- ✓ Make a habit of checking to be sure the motor is securely bolted to its platform. Mounting bolts can vibrate loose.
- ✓ Also make sure rotating parts aren't rubbing on stationary parts of the motor, causing damage.

#### *Maintenance Tasks*

- **At season startup:**
  - ✓ Remove tape on all openings. Clean out rodents, insects, and debris.
  - ✓ Locate the motor drain hole on the base or support for the base and clean it out so water won't be trapped and held directly under the air intake.

- ✓ Change oil in reduced voltage starters using an oil recommended by the manufacturer. Be sure to clean the oil pan before refilling.
- ✓ Use vacuum suction or air pressure to remove dust and debris from moving parts of motor. (Don't exceed 50 psi of air pressure.)
- ✓ Especially on large motors, you may want your electrician to do an annual Megger check on the control panel, motor, conduits, and other electrical connections. The Megger device applies a small voltage to an electrical component and measures electrical resistance. Tracking changes in readings over time allows you to diagnose looming failures due to degrading insulation.

#### Periodically:

- ✓ Clean grass and debris from air ventilation openings on and around the motor to allow a full flow of cooling air.
- ✓ Check screens on motor ventilation openings. Replace with machine cloth (¼-inch mesh) as necessary.
- ✓ At end-of-season shutdown, cover the motor with a breathable, water-resistant tarp.

### Motor Electrical System

Winter temperatures can cause electrical connections (especially in aluminum wire) to expand and contract, loosening connectors that were tight in the fall and causing heat buildup and arcing at electrical terminals. The voltage drop across loose connections also causes the motor to operate at less than its rated voltage, increasing internal motor temperature and breaking down motor winding insulation, resulting in electrical shorts and motor failures. A loose or broken connection can also unbalance the phases of three-phase power and damage the motor windings.

**! Caution: Before conducting any of these tasks, be sure power is off at the utility disconnect switch. It may be necessary to have the utility company shut the power off.**

## **Maintenance Tasks**

### **At season startup:**

- ✓ Inspect motor winding insulation. If windings are excessively grease-covered, consult your motor repair shop for direction.
- ✓ Check all safety switches following manufacturer's directions.

### **Twice per year:**

- ✓ Check electrical connections from meter loop to motor for corrosion and clean if necessary. Coat the wiring (especially aluminum) and connectors with an antioxidant that meets electrical code requirements.
- ✓ Check electrical connections from meter loop to motor for tightness. Tighten and re-tape if necessary.
- ✓ Replace overheated connections or wires with new material. Overheated connections will show heat damage such as burnt insulation on wires.

## **Motor Bearings**

Lubricate the motor according to manufacturer's instructions. Lubrication intervals depend on motor speed, power draw, load, ambient temperatures, exposure to moisture, and seasonal or continuous operation. Electric motors should not be greased daily. Bearings can be ruined by either over- or under-greasing.

Fill a grease gun with electric motor bearing grease and label it so it won't be confused with other types of grease.

**! Caution: Follow instructions in owner's manual if different from the ones given here. Newer motors may have sealed bearings that cannot be lubricated.**

### ***Recommended Re-greasing Periods for Motors***

	<b>Horsepower Range</b>		
<b>Type of Service</b>	<b>1 - 9</b>	<b>10 - 40</b>	<b>50 - 150</b>
Normal Duty (8-hour day)	8 months	6 months	4 months
Heavy Duty (24-hour day)	4 months	3 months	2 months

## *Maintenance Tasks*

○ At recommended intervals:

- ✓ Change grease to remove any accumulated moisture:
  - Remove the bottom relief plug and clean hardened grease out of passage way.
  - Using a grease gun, fill housing with approved high-temperature electric motor bearing grease (refer to the manufacturer's manual for API number of grease) until old grease is expelled.
  - Run motor until all surplus grease is thrown out through the bottom grease port (may require 5 to 10 minutes).
  - Shut off motor and use a screwdriver or similar device to remove a small amount of grease from the grease port to allow for grease expansion during full load operation.
  - Replace grease plug.

**!** **Caution: Do not overgrease your motor. If old grease is not expelled as new grease is pumped in, stop adding grease and have your motor checked by a qualified repair person. Adding new grease without old grease being removed could blow seals and push grease into the motor. Grease forced into motor windings will cause the motor to overheat and reduce service life.**

## **Control Panel**

---

### *Control Panel Safety Precautions*

**!** **Caution: Never use the main disconnect to start or stop your motor. It's not meant for this purpose and abusing it in this way will cause excessive wear of the contacts and arcing. Use the start and stop button.**

**!** **Caution: If overhead lines to your control panel's service are obstructed by tree branches or other items, have your utility company clear the lines.**

Have an electrician inspect your panel to ensure that:

- ✓ Control circuits are protected with the correct size and type of fuse.
- ✓ Lightning arresters are properly installed on meter and motor side of buss and breaker and mounted in a secure box to protect you if they blow up.
- ✓ The service panel is properly grounded, independently from the pumping plant.
- ✓ Service head grommets are in place and in good condition.

**! Caution: After opening the control panel but before touching controls inside, use a voltmeter to BE SURE the incoming power is disconnected or turned off. If necessary, have your utility disconnect the power. If you have any doubts about the safety of your control panel, WALK AWAY and call a qualified electrician. Even a current of 15 milliamps (one milliamp is one one-thousandth of an amp) can cause serious injury or death. Always play it safe!**

### *Maintenance Tasks*

 At season startup:

- ✓ Replace fuses after checking to be sure they aren't blown. Never use oversized fuses.
- ✓ Operate the disconnect switch slowly to check for alignment of blades and clips. Open and close the switch several times to clean oxide from contact points.
- ✓ Clean contacts of dust and dirt. Use very fine sandpaper or a fine file for copper contacts. Never file silver or silver-plated contacts! Replace pitted or burned contacts. Leave contacts clean and dry so dust won't collect.
- ✓ If accessible, check magnetic starter switch contact points.
- ✓ Clean out debris, rodent droppings, and nests and insects. Make sure the drain hole is open.

**Periodically:**

- ✓ Any time the main disconnect switch has been left open or off, operate it several times before leaving it closed or on. Copper oxide can form in a few hours and result in poor contact, overheating, poor grounding, and direct or high-resistance shorts.

**At shutdown (end of season):**

- ✓ Ensure that switches are in the off or open position. Lock panel in the off position and remove fuses to prevent accidental startup, vandalism, and corrosion.
- ✓ Protect exposed control boxes against moisture and dust with a waterproof tarp.

## **Engines: Diesel, Gasoline, Liquid Propane Gas (LPG), and Natural Gas**

---

***General***

- ✓ Make a habit of checking to be sure the engine is securely bolted to its platform. Mounting bolts can vibrate loose.
- ✓ Regularly check coolant, oil levels, fuel, and fan belts. If coolant or oil level is down, check lines for leakage. On diesel engines, check injectors and fuel lines for leaks.

***Maintenance Tasks***

- **At season startup:**
  - ✓ Remove tape on all engine openings and distributor cap, and tighten belts.
  - ✓ Charge batteries and connect them.
  - ✓ Open fuel tank shutoff valve.
  - ✓ Before starting the engine, override safety switches that protect against low water pressure, loss of oil pressure, and overheating. After engine has reached operating speed, activate the safety switches.
  - ✓ Run the engine for 10 minutes, then turn it off and check oil and coolant levels.
  - ✓ Check engine and pump for leaks caused by drying gaskets.

- !** Engines are affected by altitude and air temperature.
- Derate engine power output by 3.5% for every 1,000-foot increase in altitude over 500 feet above sea level and by 1% for each 10-degree increase in air temperature above 85 degrees F.

## Engine Air System

Always replace disposable air filters with new ones. Cleaning will distort the filter and allow more dirt to enter.

### Maintenance Tasks

○ At season startup:

- ✓ Clean and refill the filter bath in oil-bath air cleaners and reassemble air cleaner.

Periodically:

- ✓ Brush blockage off screen if the air-induction system is equipped with a pre-screener.
- ✓ Change the air filter only when the service indicator signals that it's time to change it:
  - Turn off the engine before changing air filter.
  - Wipe the outside of the cover and housing with a damp cloth and remove the cover.
  - If cover is dented or warped, replace it.
  - Use extreme care when removing the filter to prevent dirt from falling into the intake duct. Use a clean damp cloth to wipe inside of filter housing.
  - Install new air filter.

## Engine Electrical System

If you have a natural gas engine, note that natural gas has a higher octane value than gasoline. You can increase engine efficiency and reduce fuel consumption by setting the ignition timing to take advantage of the higher octane. Consult the engine manufacturer for recommendations on how to do this.

## *Maintenance Tasks*

### At season startup:

- ✓ Inspect breaker points for wear and replace if needed.
- ✓ Set the gap or dwell angle and lubricate rotor.
- ✓ Check timing and adjust if necessary.
- ✓ Clean all connecting terminals; cover with protectors.
- ✓ Spray silicone on electrically operated safety switches and ignition system to prevent corrosion.

### Twice per year:

- ✓ In engines that have them, clean and re-gap spark plugs or replace with plugs in the recommended heat range.
- ✓ Check all terminals and electrical connections for tightness and corrosion and spray with corrosion inhibitor (NOT grease).
- ✓ Remove the distributor cap and lubricate governor weights with silicone (NOT oil).

## **Engine Oil and Lubrication**

Have a sample of engine oil analyzed for contaminants, which signal abnormal wear. Intervals between analyses depend on your engine, and these tests may only be cost-effective for larger engines. Equipment dealers should know where oil can be analyzed and how often this should be done.

Use only oil recommended by the manufacturer. Tag each engine with a label identifying the proper oil.

## *Maintenance Tasks*

### Twice per year:

- ✓ If engine was not protected during shutdown, or if oil has not been changed within the last year, change the crankcase oil and oil filter.
- ✓ Lubricate all engine accessories such as the driveshaft and U-joints.

## Engine Fuel and Coolant

### *Maintenance Tasks*

○ Twice per year:

- ✓ Remove and clean or replace the fuel filter.

### Periodically:

- ✓ Check to be sure the fuel tank cap and oil filter cap are on tight and gaskets aren't cracked.
- ✓ Check to be sure fluid level and degree of coolant protection are adequate, the radiator cap is on tight, and gaskets aren't cracked.

### At shutdown (end of season):

- ✓ Drain all fuel from the tank and lines and shut off the fuel valve. If LP gas is used, drain vaporizer-regulator. (Drain both fuel and water lines.)
- ✓ Remove spark plugs. Pour a tablespoon of clean motor oil into each spark plug hole. Position spark plug wire away from cylinder opening and rotate crankshaft by hand to lubricate piston and rings. Replace spark plug.
- ✓ Seal distributor cap with a sealant appropriate to your climate, where the cap joins the distributor housing.
- ✓ Seal all the openings in the engine with a sealant appropriate to your climate, including air cleaner inlet, exhaust outlet, and crankcase breather tube.
- ✓ If the engine coolant is water, drain and refill the cooling system with water, a rust inhibitor, and antifreeze.
- ✓ Remove tension from belts.
- ✓ Remove and store batteries in a cool but not freezing location. Never store batteries directly on concrete.
- ✓ If engine is outdoors, cover with a water-resistant tarp.

# Centrifugal Pumps

---

## *General*

To avoid water leaks, make sure all gaskets are the correct ones for the coupling or flange. (See sidebar on gaskets on page 36.) Eliminate air leaks in your pump's suction line by coating threaded connections with pipe cement or white lead and drawing them tight. Also examine suction line welds for cracks that allow air leaks.

If the pump isn't delivering water, verify that the shaft is turning in the direction of the arrow on the casing. As viewed from the motor end, rotation is usually clockwise, but check instructions that came with the pump. On three-phase motors, swap any two power leads to change rotation. It is recommended that a qualified electrician perform this task.

If the pump doesn't prime, check for air leaks on discharge valves. Many all-metal gate-type valves won't seal properly to create a vacuum. Sand or other debris between the rubber flap and the valve seat will also prevent check valves from sealing and forming a tight joint. If the rubber face is cracked or chipped and not seating, replace the gate valve or check valve. Check connections between pump and primer. On a hand primer, if grass or other debris is lodged in the check valve, air is pulled back into the pump at every stroke and the pump won't prime. After proper priming, fill the system slowly.

## *Maintenance Tasks*

### At season startup:

- ✓ Using new gaskets and pipe dope, reconnect to the pump any piping removed during shutdown.
- ✓ Re-install the primer and priming valve if they were removed during shutdown.
- ✓ Check pump for leaks caused by drying gaskets.

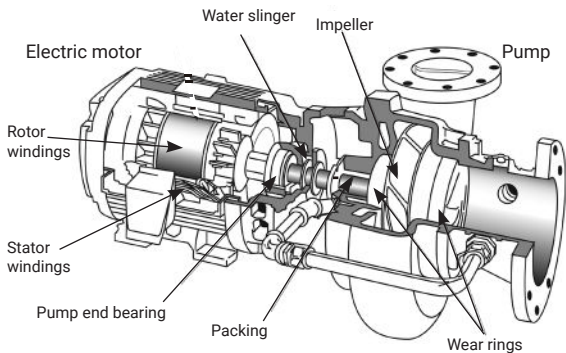

**Figure 4. Centrifugal Pump and Electric Motor**

- ✓ Check to be sure the pump shaft turns freely and is free of foreign objects. Applying power could break the impeller if it's rusted to the case.
- ✓ Check intake and discharge piping for support. Make sure pump is securely bolted to platform.
- ✓ Clean drain hole on the underside of the pump.

**Twice per year:**

- ✓ Thoroughly clean suction and discharge piping and connections of moss and debris.
- ✓ Tighten all drain and fill plugs in the pump volute case to avoid air and water leaks. Use a pipe thread compound on all pipe threads.
- ✓ Check for cracks or holes in the pump case.
- ✓ Clean trash screening device and screens on suction pipe.

**At shutdown (end of season):**

- ✓ All water **MUST** be drained prior to freezing weather.
- ✓ Remove suction and discharge piping in areas where ice is a problem. Make sure drain valves aren't plugged and drain water from the pump.
- ✓ Cover any exposed metal, such as the shaft, with protective lubricant to prevent corrosion.

- ✓ Cover all oil- or grease-lubricated bearings with lubricant so moisture won't rust and pit them.
- ✓ Remove tension from any belts.
- ✓ Open petcock and drain diaphragm-type hand primer.
- ✓ If discharge primer valve is equipped with a rubber seat, coat it with rubber preservative.
- ✓ Any rubber parts in a flexible coupling connecting the pump to the driver should also receive a coating of preservative.
- ✓ Make sure the ball valve on pressure gauge riser is closed. Remove the gauge and store it indoors.
- ✓ Seal all openings, including suction, discharge, and primer, to keep out rodents and foreign material.
- ✓ Cover the pump with a waterproof tarp.

### Servicing Impeller and Wear Rings

If you suspect your impeller is clogged with foreign matter, damaged, or has worn wear rings, you can dismantle the pump. This is not easy and best done in the shop. Or have a qualified pump repair shop undertake this procedure. Follow the directions in the manufacturer's manual, if available, instead of the simplified directions below.

- Remove suction cover or volute case.
- Remove debris from impeller and volute. Remove pebbles lodged between vanes.
- Check wear at impeller eye and vanes. If worn, repair or replace the impeller.
- Re-machine or replace wear ring if clearance is more than  $1/32$  inch per side.
- Replace suction cover or volute. Use a new gasket.

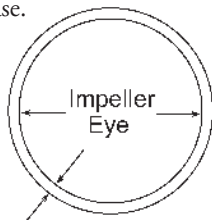

$1/32$ " clearance  
Figure 5. Impeller Eye and Wear Ring

## Net Positive Suction Head (NPSH) and Cavitation

---

A centrifugal pump doesn't pull water from a source; it can only pump water that is delivered to it. When air is removed from a suction pipe, as for example by a primer pump, the weight of the earth's atmosphere forces water to rise into the pipe. The maximum height that water can rise in a pipe under a given set of conditions is known as *Net Positive Suction Head*, or NPSH.

Under a perfect vacuum and at sea level, atmospheric pressure can theoretically force water to rise as much as 34 feet into a pipe, but this number drops with any increase in elevation, water temperature, or pipe friction. Practically speaking, centrifugal pumps more than 20 feet above a source water are likely to experience problems.

Insufficient NPSH often occurs when starting irrigation pumps. Since the pump is working against low pressure, it moves a larger-than-normal volume of water, increasing friction losses in the suction line and reducing NPSH. Insufficient NPSH leads to water vaporizing in the eye of the impeller, causing *cavitation*—a noisy condition where vapor bubbles collapse violently in the pump.

If cavitation is allowed to continue, the pump impeller and pump casing can become pitted and damaged. To stop cavitation that is occurring, close the discharge valve. To eliminate pump cavitation and water hammer, and to prevent high amperage draw on demand meters, open the discharge valve SLOWLY to fill the mainline every time you start the pump.

- ! **Caution: Never let the pump run more than**
- **two minutes with the discharge valve closed.**

## Servicing Pump Packing

A properly adjusted pump with shaft sleeve and packing in good condition shouldn't require constant readjustment but should be checked daily. If proper leakage (about 8 to 10 drops per minute) isn't running through the packing box, the packing will get overheated and dry out, eventually burning and scoring the shaft sleeve. Excessive dirt, silt, or sand in the water can also score the sleeve.

Check for an improperly greased or worn rotary shaft seal by running the pump and squirting oil on the shaft just outside the seal. Oil drawn into the seal indicates a leak.

If the pump has been out of service, the packing may be dried and hardened. Air can leak into the pump through the packing box and the pump can lose prime..

### *Pump Packing Maintenance Tasks*

#### Annually:

- ✓ Grease packing box with a proper pump packing grease. Less frequent maintenance causes grease to harden, making this task very difficult.
  - If packing box is equipped with a grease cup or zerker, apply a couple pumps of grease to the box to force out the remaining water and protect the packing.
  - For a packing box without a grease cup or zerker, remove the last two packing rings and pack packing grease into the packing box until full. Add two new rings and tighten the packing gland slightly to force the grease into the subsequent packing rings. Then loosen the gland.

### *Replacing the Packing*

Old packing should be replaced completely if you can't reduce leakage by adding new packing rings to the old ones or if packing is dried up, scorched, or leaking excessively.

**! Caution: This task is difficult. Have a qualified pump repair shop do it. Or if attempting to do it yourself, do it in the shop rather than in the field. Helpful videos are available on the Internet showing the procedure.**

- Remove packing box gland nut with a wrench. Remove gland and packing, twisting two packing pullers 180 degrees apart into the exposed packing ring to pull each ring out of the packing box until all are removed. The lantern ring has two holes 180 degrees apart and can be removed with packing pullers.
- Replace shaft sleeve if worn or grooved. This usually requires pump disassembly. Once packing is burned and the shaft sleeve is scored, no amount of adjustment will maintain proper leakage for any length of time.
- Before replacing packing, insert the packing gland to make sure it enters freely to the gland's full depth. If it doesn't, clean out fragments of old packing and debris that may be obstructing it.
- Install new packing rings as far forward as you can reach. Install only the type and size of packing recommended by the manufacturer.
- Insert each ring separately. Push it securely into the box and seat it firmly. A small amount of packing grease applied to the packing will make this job a little easier. Never use sharp points to push the packing into the box. Use the packing gland, a wooden dowel, pliers handle, fingers, or other blunt object. Successive rings of packing should be installed so the joints are 120 degrees apart.
- Reinstall lantern ring (if required) in proper position to the packing rings as shown on your manual's parts page.
- Install packing gland so it enters the stuffing box straight and with all packing under uniform pressure.
- Seal gland with clip, stud, and nut.
- If packing box is equipped with a grease fitting, add a shot of grease. If there's no grease fitting, pack grease into the packing box until it's full, before inserting the last two packing rings. Add the last two rings and tighten the packing gland slightly to force the grease into the subsequent rings of packing. Then loosen the gland.

- Start pump with the packing gland loose so there is initial leakage. Tighten the packing gland only enough to draw the necessary vacuum for priming.
- Tighten gland nuts slightly and evenly every 15 to 20 minutes until leakage is reduced to 8 to 10 drops per minute or until water leaking from the box is cool.

**! Caution: Don't stop leakage entirely.**

## Vertical Turbine Pumps

*Vertical turbine pumps* are centrifugal pumps whose impellers are connected by a vertical drive shaft to an above-ground motor or engine. They may have more than one impeller (*multi-stage*), and the drive shaft is either enclosed in a tube and oil-lubricated or else exposed and lubricated by water. Pumps less than about 50 feet in length are often called *short-set* while longer pumps are often called *deep well*, *deep-set*, or *long-set*.

### General Points

- ✓ Make a habit of periodically checking that discharge piping is firmly supported in the area near the pump. Make sure the pump is securely bolted to its platform.
- ✓ If your pump is installed over a well, and you've experienced water supply problems, check static level and drawdown in the well. A deeper pump setting might be required.

### Maintenance

○ Maintenance procedures vary depending on pump length, whether it's water- or oil-lubricated, and other factors.

#### At season startup:

- ✓ For water-lubricated pumps, pre-lubricate line shaft bearings with light oil.
- ✓ For oil-lubricated pumps, change oil in the oil bath or reservoir for the upper bearings. Fill with approved

turbine oil almost to the top of the sight of glass so bearings are covered. Make sure excess oil doesn't get on or in the motor.

- ✓ For oil-lubricated short-set pumps, start oil flowing to the pump one hour before starting the pump. Check to be sure the oil tube is filled before running the pump. The pump needs about 10 drops per minute.
- ✓ For oil-lubricated deep well pumps, start lubricating the shaft up to a week before starting the pump, or until the line shaft and column are full of oil and the oil begins to run out at the top near the stretch assembly. During this first week, allow 4 to 5 drops of oil per minute. After starting, increase to 10 to 15 drops of oil per minute. Check manufacturer's instructions to be sure of the requirement. (Oil will drip slower at night when it cools down.) The viscosity rating of the oil should be 9 or 10.

**Annually (or according to manufacturer's instructions):**

- ✓ Change bearing oil in vertical hollow shaft motors. Follow your motor manufacturer's instructions for the correct oil.

**Periodically:**

- ✓ Grease lower bearings. Refer to electric motor bearing greasing instructions on pages 11-12 and check your manufacturer's operation and maintenance literature for specifics to your equipment.
- ✓ Maintain packing as described on pages 22–24.
- ✓ Maintain bearing oil at the proper level. Overfilling the reservoir can cause oil to overflow when the motor heats up during operation. Excess oil will adhere to the motor and ventilation screens, collecting dirt and debris and reducing the motor's ability to dispel heat.

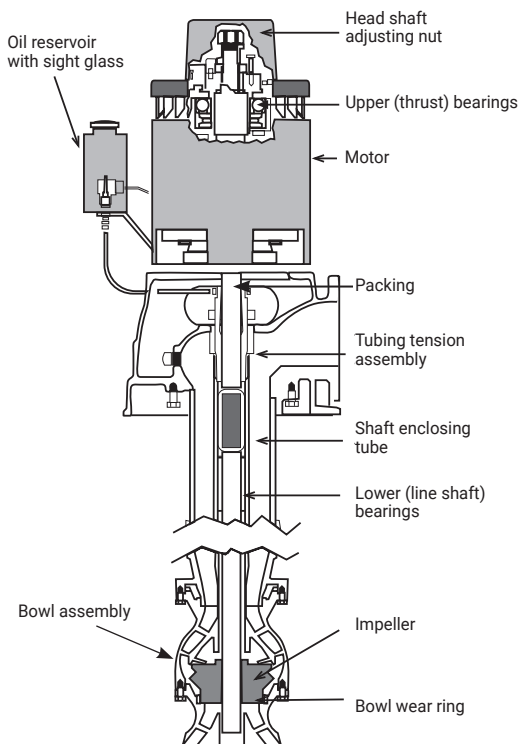

Figure 6. Oil-Lubricated Turbine Pump

### *Shaft Lift Adjustments*

Impellers need to be positioned so they can spin freely, without rubbing on the top or bottom of the bowl. Raising or lowering impellers within their bowls can also improve pump efficiency and performance and is critically important for pumps with *open impellers*, ones whose vanes are exposed on the suction side.

This is not something you should need to do often, but impellers should be checked and adjusted about every

three to five years, or more often if you are pumping sand. On some vertical turbines, especially short-set pumps with *closed impellers*, the adjustment is relatively straightforward and you may be able to do it yourself, using the head shaft adjusting nut, which is accessed by removing the top motor cover.

The adjustment procedure varies depending on the pump but usually involves raising the impellers an exact distance (or number of turns of the adjusting nut) from the bottom of the bowl. (Sometimes the procedure involves lowering the impellers an exact distance from the top of the bowl.) Follow your manufacturer's instructions or consult your pump dealer. Helpful videos are also available on the Internet showing the procedure.

**!** **Caution: Pumps more than about 100 feet long**  
• **experience shaft stretch or elongation, and only qualified service personnel should try to adjust the shaft lift on deep well turbines. Deep well pumps require advanced maintenance skills and adjustment must be very precise. Even a small miscalculation can cause severe pump damage.**

**!** **Caution: If, after adjusting, you can't turn the shaft**  
• **easily by hand, remove the pump, disassemble, and inspect for damage or debris. If you have any questions about this procedure consult your pump dealer.**

## For Further Reading

A.W. Chesterton Company pump maintenance videos  
[youtube.com/@AWChestertonCompany/videos](https://www.youtube.com/@AWChestertonCompany/videos)  
*Includes a five-part series on pumping packing installation*

Cornell Pump. **Packing and Lantern Ring: Installation, Removal, and Grease Cup** (video). [youtube.com/watch?v=uZRG4RAgdFQ](https://www.youtube.com/watch?v=uZRG4RAgdFQ)

The Hydraulic Institute website. [pumps.org/](https://www.pumps.org/)  
*Largest association of pump manufacturers in North America, offering application guidebooks, online tools, and calculators.*

**Intro to Pumps** website. [introtopumps.com/](http://introtopumps.com/)

*Introduction to pump fundamentals, offering education and engineering training through online courses and other resources.*

Scherer, Thomas. 2022. **Irrigation Water Pumps**. North Dakota State University publication AE1057. [ndsu.edu/agriculture/sites/default/files/2022-02/ae1057.pdf](http://ndsu.edu/agriculture/sites/default/files/2022-02/ae1057.pdf)

*Overview of operating characteristics, power requirements, design considerations, and maintenance for all types of irrigation pumps.*

USDA Natural Resources Conservation Service. 1997.

**Irrigation Guide: Section 15 of the National Engineering Handbook**. [directives.sc.egov.usda.gov/OpenNonWebContent.aspx?content=17837.wba](http://directives.sc.egov.usda.gov/OpenNonWebContent.aspx?content=17837.wba)

*Comprehensive guide to all aspects of irrigation system design and management. See especially the discussion of pumps and motors in Chapter 12, Energy Use and Conservation.*

Vogel, Eugene. 2020. Pumps & Systems website. **Making Shaft Lift Adjustments in Vertical Turbine Pumps**. [pumpsandsystems.com/making-shaft-lift-adjustments-vertical-turbine-pumps](http://pumpsandsystems.com/making-shaft-lift-adjustments-vertical-turbine-pumps)

## Submersible Pumps

*Submersible pumps* have motors that are below the pump and submerged in water. Compared to vertical turbines they are somewhat less efficient and more susceptible to certain types of failure, but also silent, easier to handle, and have fewer moving parts.

Most submersibles need relatively little maintenance, but motor repairs require pulling the system out of the well. Inadequate water circulation may cause the motor to overheat and burn out. The riser pipe must be long enough to keep the bowl assembly and motor completely submerged at all times. The well casing must be large enough for water to flow easily past the motor. Electrical wiring from the pump to the surface must also be watertight, with sealed connections.

# Troubleshooting

Find your symptoms and then look across the table to see possible causes. Most often, suction problems are the cause. Contact your pump repair shop for additional help.

**!** This troubleshooting guide is general and does not cover all possible system configurations or problems.

Cause of Suction Problems	Symptoms									
	Pump does not deliver water	Pump has insufficient capacity (gpm)	Pump loses prime after starting	Pump has insufficient pressure	Pump requires excessive power	Packing box leaks water excessively	Packing box has short life	Pump vibrates or is noisy	Bearings have short life	Pump overheats and seizes
Pump not primed	•	•								•
Insufficiently submerged suction pipe inlet	•	•	•							
Pump or suction pipe not completely filled with water	•	•	•				•			
Insufficient Net Positive Suction Head (NPSH — See page 21 for explanation)	•	•					•			•
Suction line, strainer, or centrifugal pump balance line plugged		•					•			
Air leaks into suction line		•	•							
Air leaks into pump through packing box		•	•							
Excessive air or gas in the water		•	•	•						
Foot valve too small, insufficiently submerged, or partly clogged				•				•		

## Cause of System Problems

Speed (rpm) too low	●	●		●						
Parallel operation of pumps unsuitable	●	●		●						●
Total system head higher than pump design head	●	●		●	●					
Wrong direction of pump rotation	●			●	●					
Speed (rpm) too high					●					
Total system head lower than pump design head					●					

Pump does not deliver water	Pump has insufficient capacity (gpm)	Pump loses prime after starting	Pump has insufficient pressure	Pump requires excessive power	Packing box leaks water excessively	Packing box has short life	Pump vibrates or is noisy	Bearings have short life	Pump overheats and seizes
●	●		●						
●	●		●						●
●	●		●	●					
●			●	●					
				●					
				●					

## Cause of Pump Problems

Rotary shaft seals (packing) leak air	●								
Foreign matter in impeller	●	●		●			●		
Wear rings worn				●	●				
Impeller damaged				●			●		
Defective pump casing gasket allowing internal leakage				●					
Misaligned pump & driving unit					●	●	●	●	●
Bent shaft between pump & motor / engine					●	●	●	●	
Rotating part rubbing stationary motor part					●		●	●	●
Packing gland too tight. No flow to lubricate packing and shaft.					●		●		
Packing worn, improperly installed, or wrong for operating conditions					●	●	●		
Cooling water not getting to water-cooled packing boxes							●		
Packing forced into pump interior						●	●		
Shaft or shaft sleeves worn or scored at the packing						●	●		

●									
●	●			●			●		
				●	●				
				●			●		
				●					
					●	●	●	●	●
					●	●	●	●	
					●		●	●	●
					●		●		
					●	●	●		
						●	●		

## Symptoms

### Cause of Pump Problems, continued

	Pump does not deliver water	Pump has insufficient capacity (gpm)	Pump loses prime after starting	Pump has insufficient pressure	Pump requires excessive power	Packing box leaks water excessively	Packing box has short life	Pump vibrates or is noisy	Bearings have short life	Pump overheats and seizes
Shaft running off-center					●	●	●	●	●	
Impeller or rotor (electric motors) out of balance					●	●	●	●	●	
Bearings worn						●	●	●	●	
Foundation or platform not rigid or mounting is loose							●			
Pipe not supported							●	●		
Under- or over-greasing of bearings or greasing sealed motor bearings							●	●		
Condensation of atmospheric moisture in bearing housing							●	●		
Lack of or improper lubrication							●	●		
Scoring or rusted bearings (turbine pump)							●	●		
Improperly installed bearing, incorrectly assembled stacked bearings, unmatched bearings used as a pair (turbine pump)							●	●		
Excessive thrust, seen as shaft movement from mechanical failure or failure of hydraulic balancing device							●	●	●	

## Pumping Plant Maintenance Form

Field # \_\_\_\_\_ Year \_\_\_\_\_ Begin date \_\_\_\_\_ End date \_\_\_\_\_

Date pump start-up \_\_\_\_\_ Beginning PSI \_\_\_\_\_

Midseason PSI \_\_\_\_\_ Date \_\_\_\_\_

End of season PSI \_\_\_\_\_ Date \_\_\_\_\_

Motor amps \_\_\_\_\_ Test date \_\_\_\_\_

Motor amps \_\_\_\_\_ Test date \_\_\_\_\_

**Pump:**

**Motor:**

Installation Date \_\_\_\_\_ Installation date \_\_\_\_\_

Dealer \_\_\_\_\_ Dealer \_\_\_\_\_

Mfr. \_\_\_\_\_ Mfr. \_\_\_\_\_

Model \_\_\_\_\_ Model \_\_\_\_\_

Serial no. \_\_\_\_\_ Serial no. \_\_\_\_\_

Rated head \_\_\_\_\_ Rated horsepower \_\_\_\_\_

Rated flow \_\_\_\_\_ Service factor \_\_\_\_\_

Repair date \_\_\_\_\_ Repair date \_\_\_\_\_

By \_\_\_\_\_ By \_\_\_\_\_

Desc. of repair \_\_\_\_\_ Desc. of repair \_\_\_\_\_

\_\_\_\_\_

**Date Replaced / Serviced**

**System 1**

**System 2**

Gauges \_\_\_\_\_

Motor bearings \_\_\_\_\_

Pump packing \_\_\_\_\_

Oil change \_\_\_\_\_

Filters \_\_\_\_\_

Hoses \_\_\_\_\_

Cooling system \_\_\_\_\_

Lube \_\_\_\_\_

Adjust turbine bowls \_\_\_\_\_

Primer pump \_\_\_\_\_

\_\_\_\_\_

\_\_\_\_\_

## 3. Distribution System Maintenance

### Sprinkler Systems

---

#### General

Ideally, aluminum mainlines should be raised off the ground with short boards or old tires to allow air circulation and prevent corrosion.

Lay out mainline and handline pipe as straight as possible to minimize friction loss through couplers. Install air relief valves and vacuum relief as needed on high points of mainline and air relief at end of the mainline. Set mainline pressure relief valve at 10 psi above normal operating pressure or at the pressure specified to protect piping.

**! Caution: Irrigation pipes are one of the most common sources of human contact with power lines. To avoid serious injury or electrocution, always look up for power lines BEFORE you start work. Treat all overhead power lines as though they were bare and uninsulated. Keep vehicles, equipment, tools, and people at least 10 feet away from power lines. When lifting, pipe sections, never raise the end of a pipe higher than your head. Never stand a pipe on its end, or you could hit a power line.**

#### Sprinkler Heads

To make sprinkler system maintenance less of a chore:

- Always keep a few extra nozzles and sprinkler heads on hand for quick repairs.
- Use a box-end wrench to remove and replace sprinkler nozzles. Open-end or pipe wrenches will damage nozzles.
- When reinstalling sprinkler heads, wrap threads with Teflon plumber's tape. Petroleum-based pipe-dope compounds cause early deterioration of rubber washers. Also, don't lubricate sprinkler heads for either storage or operation.

- When installing new sprinkler heads, spray a dab of paint on the new heads. Avoid getting overspray on rubber or moving parts. Spray the same color on your shop wall and note the year, using a different color for each year. Since sprinkler heads last one to five years, four or five colors are enough.

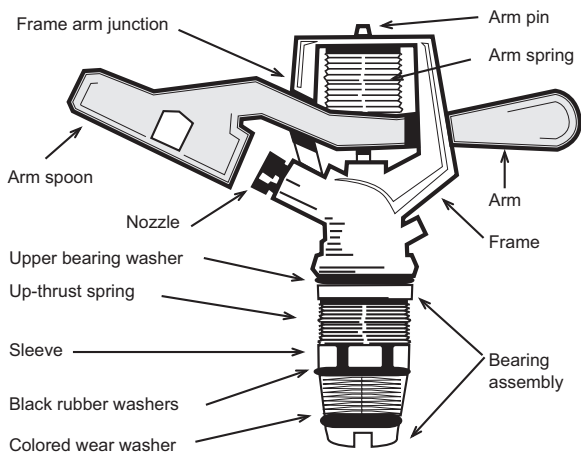

Figure 7. Sprinkler Head

Remember that broken or weak springs cause uneven spray patterns and reduced production due to uneven water distribution.

If your cropland is rolling, with significant elevation changes, consider *flow control nozzles*. These nozzles will compensate for pressure differences caused by elevation changes. Most models are only effective, however, at pressures between 25 psi and 55 psi.

### 🔧 *Maintenance Tasks*

#### ○ Daily:

- ✓ Check that nozzles aren't plugged. Unplug nozzles with something softer than the material they are made of.

*Never hammer a head to dislodge a plug!*

## Nozzle Wear and Sizing

Over the years, or even within a season, irrigation systems often acquire a variety of nozzle sizes, resulting in widely varying amounts of water put on the crop.

For example, at 50 psi a 9/64" nozzle puts out 4.1 gpm, an 11/64" nozzle puts out 6 gpm, and a 13/64" nozzle puts out 8.5 gpm. If you mix 9/64" and 13/64" nozzles, you could be applying 0.2" water per hour on one part of the field and over 0.4" of water per hour on another part. Worn nozzles would show an even wider variation.

Normally, sprinkler nozzle size should be the same along the length of a lateral. (Center pivots are an exception.) If you're unsure of the correct nozzle size for your system, contact your irrigation equipment dealer.

- ✓ For other problems, such as bent arms, broken springs, or broken arm pins, replace the head with one of your extras.

### At shutdown (end of season):

- ✓ Remove a few two- or three-year-old sprinkler heads. If some show wear, remove all sprinkler heads of the same age and check for nozzle wear and worn washers and springs. Replace worn nozzles and heads as needed.

## Mainlines and Lateral Pipes

### 🔧 *Maintenance Tasks*

- At season startup:
  - ✓ Clean pipe of animal nests.
  - ✓ Inspect for bent or flattened piping, split seams, and punctures. Use a slightly tapered wooden plug of proper diameter to round out any damaged ends.
  - ✓ Reassemble couplers, gaskets, risers, and sprinkler heads. Replace damaged gaskets. Gaskets shrink and admit air. Tighten flanges or connections, or replace gaskets.
  - ✓ If mainline valves leak, replace valve plates or lids.

## Choosing Gaskets

Using a gasket in a coupling that it was not made for is a common cause of leaky gaskets.

**Flat gaskets:** Most are made of neoprene and are used on flanged, bolt-together fittings. They are usually not expensive. They normally fail by “creeping” out of their fitting. Look for new neoprene gaskets that contain a cotton backing sandwiched in the gasket to reduce the creeping action.

**Shaped gaskets:** The three most common materials are styrene-butadiene (SBR), ethylene-propylene (EPDM), and polyethylene (poly). SBR and EPDM have much better resistance to cracking, abrasion, ozone, and weathering resistance than poly gaskets. They’re more expensive than poly but will last longer. When buying shaped gaskets, look for gaskets that are dull. This indicates that little or no plasticizer has been added to the gasket. Plasticizers significantly reduce gasket life.

- ✓ If your mainline valves have grease zerks, lubricate according to manufacturer’s instructions.
- ✓ Tap exposed steel pipe with a rubber hammer before startup to release rust.
- ✓ Flush entire system thoroughly with end plugs and wheel line drains removed to prevent plugging nozzles and pressure regulators with dirt, rust, or other foreign material that may be in the system. Replace end plugs and drains.
- ✓ With water supplied to the lines, check all nozzles and impact sprinklers for plugging, mismatched sizes, breakage, corrosion, or other damage caused by wear or winter weather. Check couplers, connections, levelers, and drains for leaks.

### Periodically:

- ✓ In spring and fall, inspect piping for corrosion. If any is found, consult the supplier for protection methods.
- ✓ Check pipe, valves, drains, and risers for plugging from grass and other debris.
- ✓ Flush sediment from ends of laterals.

### At shutdown (end of season):

- ✓ Dismantle hand lines into sections and store on inclined racks above the ground to allow drainage and air circulation. Avoid storing pipe near acids, caustic or other chemical fumes or dusts, or animal waste.

## Wheel Line (Side Roll) Mover and Wheels

**! Caution:** The cover on the power mover should be closed unless the mover is not being worked on and especially before turning the irrigation water on. Wheel lines should never be moved with water in the pipeline.

### Maintenance Tasks

#### At season startup:

- ✓ If fuel was left in the carburetor through the winter, fuel passages may have become clogged by sediment, residue, or additives. If gas is not entering the engine cylinder, the carburetor may require adjustment or cleaning before the engine will start and operate properly.
- ✓ Remove dirt and debris from mover chain and gears of the drive mechanism. Lubricate teeth and chains with SAE 30 weight oil or grease by wearing rubber gloves and using a bucket full of grease. (Consult manufacturer or equipment dealer for the correct lubricant.) Realign drive chains if necessary.
- ✓ Open hydraulic fluid valve and check hydraulic fluid. Refill if necessary.
- ✓ Inspect the entire length of the line, checking wheels and power mover for loose bolts, equipment wear, or winter damage. Repair as necessary.

- ✓ Before starting wheel line mover for the first time in the spring, make sure drive mechanism is disengaged.
- ✓ Make sure fuel tank is free of debris. Fill with fresh fuel. If fuel tank was not emptied at shutdown, or stabilizer was not added, drain tank before filling with fresh fuel.
- ✓ Remove spark plug. Clean and set the gap. If spark plug is damaged or shows excessive heat erosion, replace it.
- ✓ To check operation of power mover, engage transmission and slowly power unit forward or backward to make sure all wheels, chains, and gears are working properly. Make sure wheel line is straight or the ends are slightly lagging behind the power mover's direction of travel.

#### **Periodically throughout the season:**

- ✓ Remove dirt, oil, and debris from exterior engine surfaces, paying special attention to cooling fins, surfaces near air intake, and carburetor linkages.
- ✓ Lubricate mover teeth and chains with SAE 30 weight oil or grease.
- ✓ Check air filter weekly. Clean or replace it after every 25 hours of operation or more frequently under dusty or dirty operating conditions. Follow manufacturer's guidelines for cleaning and replacement.
- ✓ Check engine oil once per week or every five operating hours. Change oil after every 25 hours of engine operation, using a high quality oil, or more frequently if air cleaner shows evidence of dusty or dirty operating conditions. When adding or changing engine oil, do not under- or overfill the crankcase.
- ✓ Check fluid reservoir of hydraulic transmission every 25 operating hours. Fill to proper level. Drain any water that has seeped into the reservoir.

- ✓ If fluid appears dirty, drain and replace with hydraulic fluid recommended by manufacturer. Replace inline filter in pickup line of transmission.
- ✓ Grease wheel axles and main drive hub bearings every two weeks with water-resistant multipurpose grease. Follow manufacturer's recommendations for lubrication selection and application.

#### **At shutdown (end of season):**

- ✓ Evaluate system components. Mark problems for repair: worn impact sprinklers, nozzles, leaky pipes, gaskets, levelers, and drains. Buy replacement equipment for installation in the spring.
- ✓ Flush automatic drains so they are free of sand.
- ✓ Where freezing is a concern, drain water from all pipelines and completely open valves.
- ✓ Remove end plugs from wheel lines and empty water, debris, or sediment in pipe ends. Replace plugs.
- ✓ Remove gaskets, clean off silt, sand, or other debris, and store in a dry place—ideally in a plastic bag and sprinkled with talcum powder to prevent cracking.
- ✓ After gaskets have been removed, clean couplers with water to remove foreign matter.
- ✓ Wire covers onto the ends of wheel line sections to prevent debris and rodents from entering pipe during the winter. (Coffee cans work well.)
- ✓ If livestock will be in the field, move wheel line to the end of the field and surround it with electric fence.
- ✓ To prevent wind damage to wheel lines, secure line to posts driven at every third or fourth wheel.
- ✓ Start engine and let run for a few minutes. Shut off fuel tank switch and let the carburetor run out of fuel. Drain or siphon out all remaining fuel in the tank and flush

out any debris. If you want to leave fuel in the tank, add fuel stabilizer.

- ✓ Remove spark plug and pour a tablespoon of clean motor oil into spark plug hole. Position spark plug wire away from cylinder opening and rotate crankshaft by hand to lubricate piston and the rings. Replace spark plug.
- ✓ Remove mower chain and store in a bucket of used motor oil for the winter.
- ✓ Secure engine cover by latching or tying it in place to keep wind from blowing it open.
- ✓ Avoid placing wheels in a ditch where expansion and contraction of piping can twist the wheels.

## Center Pivot & Linear Move

Most newer pivots and linear move systems operate at low pressure and include pressure or flow regulation devices that are susceptible to plugging. Even small amounts of nozzle fouling will noticeably reduce water application uniformity. The water supply for center pivot and linear move systems must be clean.

### *Maintenance Tasks*

#### At season startup:

- ✓ Clean pipe of animal nests.
- ✓ Disconnect electrical power and check that mower motor lead connections are tight and not burned or corroded.
- ✓ Make sure all equipment is properly grounded.
- ✓ Check and lubricate all valves according to manufacturer's instructions.
- ✓ Grease center pivot swivel with one full tube of grease.
- ✓ Grease the driveline if equipped with grease-type U-joints, and check for excessive wear.

- ✓ Grease all zerks liberally at least annually.
- ✓ Check tower boxes for damage and seal to keep water out if they show signs of moisture.
- ✓ Check for proper tire inflation. Uneven tire pressure is hard on gear boxes. Inflate tires (22-25 psi for 11.9-inch tires, 16-18 psi for 14.9-inch tires) and tighten lug nuts.
- ✓ Flush system thoroughly with drains removed to prevent plugging nozzles and pressure regulators. Replace drains.

#### **Annually:**

- ✓ Check gear box lubricant to ensure that it's filled to the proper level. Change oil in gear boxes at least every three years. If you operate your system more than 1,000 hours per year, change oil every other year. Follow the manufacturer's recommendations for oil type, weight, and service schedule specific to your equipment.

#### **Regularly throughout the season:**

- ✓ Inspect pipe for corrosion. If you find corrosion, consult the supplier for protection methods.
- ✓ Check pressure regulators at each sprinkler head. If water leaks out the side air hole during operation, replace it.
- ✓ Check all nozzles for wear and make sure they are spraying properly.
- ✓ Check that drains are free and working properly.

#### **At shutdown (end of season):**

- ✓ Park pivot for the winter on level ground if possible, or slightly uphill from pivot center.
- ✓ Flush automatic drains so they are free of sand.
- ✓ Where freezing is a concern, drain water from all pipelines and completely open valves.
- ✓ Where freezing is a concern, remove drain plugs from gear boxes to let water out. Then replenish with oil. Fill to  $\frac{1}{4}$  inch above the uppermost bearing, or to within  $\frac{1}{4}$  inch of the top if it has an expansion chamber.

- ✓ Booster pumps may have a mechanical seal in the packing box. If the seal wears out, replace it. Follow shutdown procedures for pumps and motors described in the *Pumping Plant Maintenance* section.
- ✓ If possible, raise tires and place boards under them, perpendicular to the line of travel, to allow movement as the system contracts and expands over winter.
- ✓ Disconnect power to center pivot or linear move system.

## Surface Systems: Ditches, Siphon Tubes & Gated Pipe

---

### *Maintenance Tasks*

- At season startup:
  - ✓ In the spring, clean ditches of mud and weeds.
  - ✓ For gated pipe, replace broken gates and clean gaskets.

#### At season shutdown:

- ✓ Where freezing is a concern, clear ditches and repair cracks in concrete liners to prevent damage.
- ✓ Store siphon tubes and system controllers under cover.
- ✓ Store gated pipe with gasket end facing north to lessen damage from sunlight, with gates closed and turned up to discourage rodents from gnawing the seals.

## Microirrigation Systems

---

Water quality is critical to maintaining microirrigation systems. Emitter clogging is the biggest problem you face.

### *Maintenance Tasks*

- Regularly:
  - ✓ Check for leaks daily or weekly. These are generally easy to spot in surface systems. In subsurface systems, watch flowmeters and pressure gauges closely. *Leaks cause increased flow rate and decreased pressure.*

- ✓ Inspect filters. Clean and replace as necessary. Backflush manually or with automatic cycle. In media filters, replace filter media (such as sand) when it begins to cake.
- ✓ Check pressure upstream and downstream from filters. Dirty filters increase pressure differential. Follow manufacturer's guidelines for acceptable pressure drop.
- ✓ Flush lines about every two weeks. If it takes more than about a minute to flush the lines clean, you may need to flush more often.
- ✓ Inspect emitters for clogging daily or weekly. Completely clogged drip emitters should be cleaned or replaced, although most are sealed and can't be taken apart for cleaning. Check flowmeters and pressure gauges as an indication of partial clogging. *Clogging decreases flow downstream from clogs and increases pressure upstream.*
- ✓ Check application rate (inches per hour) once or twice per year. For surface systems, catch flow from several emitters in a rain gauge for exactly one minute. For subsurface systems, take pressure measurements and use conversion tables provided by the manufacturer. Sudden changes indicate partly clogged emitters, leaks, or other problems.
- ✓ Chlorinate monthly with 10-20 ppm if you have moderate clogging due to biological contamination.
- ✓ For drip emitters completely clogged with biological contaminants, try injecting 50-100 ppm of chlorine. Wait 24 hours, then thoroughly flush the system.

**! Caution: Organic growers are not allowed to have**  
• **residual chlorine levels above the maximum residual disinfectant limit under Safe Drinking Water Act limit, currently 4.0 ppm. Allowed alternatives to chlorine include hydrogen peroxide, alcohols, and soap-based algicide/demisters.**

- ✓ Clogging due to mineral deposits such as lime or iron precipitates can be prevented and often remediated by injecting acid to lower pH to 6 to 6.5 every 2 to 4 weeks. (Measure with pH strips or a pool/spa test kit.)
- ✓ For emitters that are completely clogged with mineral deposits, try injecting enough acid to lower pH to 5.0. Wait 24 hours and then thoroughly flush the system.

**/ Caution: Acid can damage emitters and other irrigation components, with the greatest risk below pH 5.5. The flexible orifice in some pressure-compensating emitters is especially susceptible to acid damage.**

**/ Caution: Organic growers are generally not allowed to use synthetic acids. Many organic growers use vinegar, which contains acetic acid, if it is from a natural source.**

**/ Caution: Be careful when mixing chemicals. Wear eye protection and gloves and follow instructions. Any carelessness on your part could cause an explosion of caustic chemicals, a release of toxic gases, or a chemical reaction that will severely clog emitters.**

**/ Caution: Your system must include appropriate valves, drains, and controls to prevent backflow, which could cause chemicals to contaminate your water source or spill onto the ground.**

**/ Caution: Do not mix chlorine and acids (or acidified fertilizer) together, or store them in the same room, since they will form chlorine gas which is toxic and can cause eye and skin burns, lung damage, and even death.**

### **At season shutdown:**

- ✓ Treat entire system with 40 ppm residual chlorine concentration for at least four hours and completely flush the system.
- ✓ Drain water from all pipelines. The system may have to be blown out lateral by lateral with an air compressor. Don't exceed 15 to 20 psi of air pressure, or you'll blow off the emitters. Polyethylene pipes can withstand some freezing without breaking, so it isn't critical that all water be removed. In cases where remaining water may be a problem, add a gallon of non-toxic antifreeze (the type used in RVs) to the piping system and distribute it throughout with compressed air. More antifreeze may be necessary for larger systems.

- ! **Caution: Organic growers are prohibited from using synthetic substances such as RV antifreeze.**

## Sprinkler System Maintenance Form

Field # \_\_\_\_\_ Year \_\_\_\_\_ Begin date \_\_\_\_\_ End date \_\_\_\_\_

**System:** \_\_\_\_\_

Installation date \_\_\_\_\_ Dealer \_\_\_\_\_

Mfr. \_\_\_\_\_ Model \_\_\_\_\_

Repair date \_\_\_\_\_ Repaired by \_\_\_\_\_

Description of repair \_\_\_\_\_

**System:** \_\_\_\_\_

Installation date \_\_\_\_\_ Dealer \_\_\_\_\_

Mfr. \_\_\_\_\_ Model \_\_\_\_\_

Repair date \_\_\_\_\_ Repaired by \_\_\_\_\_

Description of repair \_\_\_\_\_

### Date Replaced or Serviced

	System 1	System 2
Nozzles	_____	_____
Heads	_____	_____
Levelers	_____	_____
Gaskets	_____	_____
Drains	_____	_____
Mainline valve plates/lids	_____	_____
Pressure regulators	_____	_____
Wheel line mover	_____	_____
Engine oil	_____	_____
Hydraulic fluid	_____	_____
Filters	_____	_____
Lube system	_____	_____
Hoses	_____	_____
Pivot drives	_____	_____
End gun booster pump	_____	_____
_____	_____	_____
_____	_____	_____

## 4. Saving Energy

You don't have control over rising electricity costs or low commodity prices, but you can stop throwing money away on inefficiencies in your system. Read the tips here on cost-effective improvements to your system. Then study the *Water Management* half of this guidebook to use your efficiently pumped water most effectively.

### Electrical Use and the Charges on Your Power Bill

---

Electricity is measured in watts or kilowatts (equal to 1,000 watts). The number of watts is the product of operating voltage times the current (or amps) flowing to the load. A kilowatt-hour (kWh) is an amount of energy equivalent to using one kilowatt (kW) over a one-hour period. To visualize one kilowatt-hour, it may be helpful to imagine ten 100-watt lightbulbs burning for one hour.

Although billing procedures vary among electric providers and in different regions of the country, irrigation bills typically include three basic charges for electricity:

1. **Base Rate or Meter Charge.** This is either a monthly or seasonal charge. Some utilities roll this charge into the electric consumption or energy rate.
2. **Electric Consumption or Energy Charge.** This charge is based on the amount of electricity used over time as recorded on the kilowatt-hour meter, with a rate charged for each kWh consumed.
3. **Electric Demand Charge.** Many utilities charge their larger customers an amount over and above the charge for kilowatt-hour energy consumption, to maintain enough capacity to serve these large customers' needs. (Customers with small motors may not have a demand charge.)

Electric providers generally calculate the demand charge in one of two ways, each intended to give an approximation of the customer's size:

- The demand charge may be based on connected load or horsepower, with a fixed rate charged per horsepower during each billing period. This charge is usually based on “nameplate” horsepower. For example, if your demand charge is \$10 per horsepower your demand charge for a 40-horsepower system would be \$400.
- The demand charge may be based on maximum wattage during the billing period. In this method, a special demand meter might measure a wattage for each 15-minute interval during the billing period. (Strictly speaking, the demand meter measures wattage every few seconds and then averages these measurements at the end of the 15-minute interval to calculate an average wattage for the interval.) The demand charge is based on the 15-minute interval during the billing period with highest wattage.

For example, suppose your demand charge is \$10 per kilowatt and your demand meter records wattage of 29 kilowatts for some 15-minute intervals in the billing period, 30 kilowatts for other 15-minute intervals, and 31 kilowatts for other intervals. You would be billed \$310. Demand charges are based on the size of your system—not how many hours you run the system. You would incur a demand charge even if you ran your system for just one 15-minute interval during the entire billing period.

You can save a lot of money by understanding how and when you're charged for electricity. Talk to a customer service representative at your utility and ask for an explanation of the rate structure. Make sure you know when your meter reading date is each month, since this can influence your management decisions. If your power bill includes a demand charge, remember that this charge will be about the same whether you operate your system one day or 31 days during a billing period.

## Every kWh Counts

---

Some irrigators mistakenly assume that since they're charged for demand, they won't save money by turning off their pumps and reducing hours of operation. It's true the demand charge is often a substantial percentage of your total electric bill. But all electric providers bill for every single kWh that is consumed. You'll always save money by reducing your hours of operation.

## Common Causes of Wasted Energy

---

### **Lack of system maintenance:**

- ✓ Develop a regular maintenance schedule. Impellers that are out of adjustment, plugged screens, worn nozzles, engine drive units that need a tune-up, worn shaft sleeves, leaking gaskets and drains, and dried out bearings and pump packing are only a few of the problems that you can avoid with regular maintenance.

### **The wrong pump for the system:**

- ✓ If your pump is oversized, undersized, or just not matched to your system, it will never operate efficiently. While it may be possible to trim the pump impeller, re-nozzle the sprinklers, or redesign the layout of the mainline and laterals, a new pump with different characteristics is most likely necessary.

### **Pump wear from cavitation or abrasion:**

- ✓ Cavitation damages pump impellers, reducing efficiency. If your pump is cavitating, determine if you have sufficient NPSH. (See page 21 for an explanation of NPSH.) You should also have a valve on the discharge side of your pump to allow filling the mainline slowly, avoiding cavitation.
- ✓ If your water source contains a lot of sediment, re-engineer your intake structure to allow sediment to settle out of the water before entering the suction line.

## Causes of High Demand

Your demand meter can alert you to problems. Track the demand amount on your power bills and compare month to month and year to year.

- Is demand increasing gradually even though you haven't made changes to your system? This might indicate leaks that are growing or increasing wear in the pump or motor bearings.
- Did demand take a sudden jump? This could signal a large leak or major problem such as motor overloading, inadequate bearing lubrication, voltage imbalance, or other problems.
- Is average demand too high for the connected horsepower? The demand reading on your power bill in kW should be about  $\frac{3}{4}$  of your connected horsepower. For example, a 40-hp pump should have a demand reading of about 30 kW if no other loads are on this meter. If a pivot mover or booster pump are on this meter, the kW will be  $\frac{3}{4}$  of the whole connected load.

### Improperly sized or designed fittings:

- ✓ Every minute that water is passing through undersized fittings such as valves, your profits are draining away. Replace those fittings with ones of the correct size.

### Water source changes:

- ✓ If the water level in your well has dropped, you may have to reset the pump at a lower level. To compensate for the increased head, you may have to add more stages to turbine or submersible pumps. If you're using surface water and the level has dropped, centrifugal pumps may need to be relocated closer to the water source in order to supply sufficient NPSH.

- ✓ If turbine or submersible pump capacities don't fit the well characteristics, you may need to replace the bowls with new ones suited to your well capacity.

### Time-of-Use Rate Schedules

---

In some parts of the country, irrigators can sign up for a time-of-use billing schedule. Under time-of-use billing, rates are higher at peak times (when demand is greatest) and lower at “off peak” times. Time-of-use billing allows some irrigators to adjust their work schedules so they irrigate when rates are low, reducing costs and avoiding power interruptions. If time-of-use billing is available in your area, call your utility to discuss this option and see if a time-of-use rate schedule may work for you.

## Hardware Improvements

---

### Electric Motors

- ✓ Rebuild your older motor and gain several percentage points in motor efficiency. This procedure typically involves replacing the bearings, rewinding, and “dipping and baking,” and is done by qualified motor repair shops.
- ✓ Consider a premium efficiency motor instead of a standard efficiency motor in all new installations, if the cost of rewinding exceeds 65% of the price of a new motor, and when replacing over- or undersized motors. Premium efficiency motors are 2-4% more efficient than standard efficiency motors and usually have higher service factors, longer insulation and bearing lives, and less vibration than standard efficiency motors.

**/ Caution: Some premium efficiency motors draw a higher startup current. Make sure your system can handle it.**

- ✓ If you're putting in a new system, be aware that an 1800 rpm motor is more efficient than a 3600 rpm motor. For example: an open drip-proof 3600 rpm, 40-hp motor is 91.7% efficient whereas an 1800 rpm, 40-hp motor is 93% efficient. Since an 1800 rpm motor makes half the revolutions of a 3600 rpm motor, maintenance needs are lower and motor life is longer.
- ✓ Consider a variable speed drive (also called a variable frequency drive, or VFD) or electronically commutated motor (for smaller motors) if you need to produce a wide range of flows and pressures to meet varying system needs. For example, a pump serving two pivots with a variable speed drive would run at a slower speed with one pivot turned on and a higher speed with both pivots operating. A variable speed drive can reduce electric demand charges on oversized pumps and during lower flow uses or seasons, while mitigating other problems caused by oversized pumps. Cost-effectiveness of a variable speed drive will depend on operating hours, pump size, and crop value.
- ✓ Constant-pressure valves or flow-control nozzles may be as effective as a variable speed drive. Contact your equipment supplier for more information.

## Engines

- ✓ Keep your engine drive in peak operating condition to reduce fuel costs and downtime. Refer to the *Engine Maintenance* section for tune-up advice.
- ✓ If your radiator-cooled engine uses a cooling fan, its efficiency is reduced by 5-8%. In other words, 5-8% of the fuel going into the engine is used to run the fan, not pump water. You can install equipment that uses the irrigation water to cool the engine, eliminating the need for a fan. Check with an equipment dealer.
- ✓ Think about using the variable speed ability of your engine to your advantage. By varying the rpm of the engine you can vary the flow rate, total dynamic head,

and brake horsepower requirements of the pump to meet varying system needs and save fuel. Consult an engine equipment or irrigation equipment dealer for advice.

## Centrifugal Pumps

- ✓ Rebuilding your older pump is often a cost-effective alternative to buying a new pump and usually involves replacing shaft sleeves, packing, and wear rings, and re-machining or replacing the impeller.
- ✓ For optimum efficiency, the pump must match requirements of your water source, water delivery system, and irrigation equipment. If your pump is under- or oversized and does not match the system needs, pump replacement is the best option. Running an oversized pump with a mainline valve half-closed is like driving your car with your foot on the brake and the accelerator at the same time.

## Turbine Pumps

- ✓ Vertical shaft turbine pumps lose efficiency if they aren't regularly adjusted. See pages 25-27 for instructions on adjusting a short-coupled turbine pump. Deep well turbine pumps should only be adjusted by qualified pump service personnel.
- ✓ Rebuilding your older turbine pump is often a cost-effective alternative to purchasing a new pump and usually involves replacing shaft sleeves, packing, and bearings, and re-machining or replacing the bowls.

## Mainlines

- ✓ Mainlines too small for the volume of water pumped through them contribute to high head requirements and lowered system efficiency. Water velocity through a mainline should never exceed 7 feet per second (fps), and velocity below 5 fps is best. Refer to the *Conversions and Formulas* section of this book for recommended maximum flow rates for different pipe sizes.

## How Leaks Cost You Money

Many irrigators aren't too concerned about leaks because "the water ends up on the field anyway." What these folks don't realize is that leaks reduce system pressure, causing a poor distribution pattern and moving the pump operating point from where it is most efficient, thus increasing demand costs. Significant leaks can also cause motor overload and shorten motor life.

### Sprinkler Systems

- ✓ Convert a high-pressure pivot with impact sprinklers to low pressure (20 to 35 pounds per square inch or psi) or very low pressure (10 psi), install drop tubes, and either reduce your pump size or have the impellers trimmed to reduce horsepower. Besides saving energy and money, you'll increase application uniformity and reduce wind drift since water will be discharged closer to the ground. Be aware, however, that a low pressure pivot could exceed your soil's infiltration rate, causing runoff.
- ✓ Sprinkler options have come a long way in recent years. *Spinners* produce larger droplets that are more rain-like and reduce wind drift. *Dual sprayheads* allow for different spray options for crop germination or irrigating later in the season. Spray plates can also be replaced to allow for different spray patterns. Check out sprinkler packages and options at your local irrigation equipment dealer.
- ✓ You can also convert your pivot to Low Energy Precision Application (LEPA), installing hoses and drag socks that apply water directly at the soil surface. These extremely low pressure systems reduce energy needs, virtually eliminate wind drift, and prevents deep wheel tracks since the ground is wet behind the wheels and not in front of them.

- ✓ Any uphill water sources? Use them! Reduce horsepower requirements or eliminate your pump completely by taking advantage of gravity if you have sufficient elevation drop. Two and three-tenths (2.3) foot elevation drop is equal to one psi of pressure. Your irrigation equipment dealer can help you determine if you can convert to a full or partial gravity system.
- ✓ If you're raising orchards or vegetable crops, consider converting to drip or micro sprinklers. They operate on very low pressure and allow precise placement of water to the plant (which also reduces weed problems).

### ***Sprinkler Nozzle Wear***

To check nozzle wear, remove the nozzle and clean out the interior. Then:

- Use a numbered drill index with bits measured in thousandths of an inch or a new high speed drill bit. If a drill bit is used, get a new nozzle to compare alongside the worn nozzle.
- Insert the index into the nozzle opening and compare the size to that printed on the nozzle.
- Or, insert the shank (smooth end) of the drill bit into the nozzle opening. The fit should be snug. If you can wobble the bit sideways even slightly, the nozzle is worn.

### **Surface Irrigation**

- ✓ Consider replacing open ditches with *gated pipe*. Gated pipe allows water to flow out through evenly-spaced “gates” or openings along the length of the pipe, giving you increased control over the way water is applied.
- ✓ If you're already using gated pipe, increase water application efficiency and reduce runoff by installing a *surge valve*. Surge flow automatically alternates the water from one set of furrows or border strips to another, smoothing the soil and causing the water

stream to advance much faster. Deep percolation at the upper end is reduced and water penetration at the lower end is increased for more even water distribution. Depending on crop value and labor costs, these systems often pay for themselves in a few years.

### How Worn Nozzles Cost You Money

---

Just a tiny bit of nozzle wear (a few thousandths of an inch) can cause a big increase in sprinkler output and seriously decrease the system's application efficiency. Worn nozzles, like leaks, are one of the most common and underrated problems with irrigation systems and a primary cause of increased electrical demand costs. They also decrease pumping plant efficiency and overload motors, leading to substantially reduced motor life. Depending on your system's total dynamic head and efficiency and your electric costs, *each* worn sprinkler nozzle might be costing you anywhere from \$0.25 to \$5.00 or more annually.

# **Handy Conversions and Formulas**



## Source

Most conversions and formulas in this section come from the USDA Natural Resources Conservation Service. 1997. NRCS Irrigation Guide: Section 15 of the National Engineering Handbook. [directives.sc.egov.usda.gov/OpenNonWebContent.aspx?content=17837.wba](http://directives.sc.egov.usda.gov/OpenNonWebContent.aspx?content=17837.wba)

## Flow Rate Conversions

Gallons Per Minute (gpm)	Cubic Meters Per Hour	Acre Feet Per 24 Hours	Cubic Feet Per Second (cfs)	Acre Inches Per 24 Hours
1	0.2270	0.004	0.00223	0.05
4.403	1		0.00981	
224.4		1	0.50	11.9
448.8	101.9	2	1	23.8
673.2		3	1.50	35.7
897.6		4	2.00	47.6
1,000.0		4.5	2.23	54.0
1,122.0		5	2.50	59.5
1,346.4		6	3.00	71.4
1,570.8		7	3.50	83.3
1,795.2		8	4.00	95.2
2,244.0		10	5.00	119.0
2,692.8		12	6.00	142.8
3,141.6		14	7.00	166.6
3,590.4		16	8.00	190.4
4,039.2		18	9.00	214.2
4,488.0		20	10.00	238.0

## Volume Conversions

---

1 ft<sup>3</sup>/sec = 50 Miner's inches in ID, KS, ND, NE, NM, SD, UT, WA, Southern CA

1 ft<sup>3</sup>/sec = 40 Miner's inches in AZ, MT, OR, NV, Northern CA

1 ft<sup>3</sup>/sec = 38.4 Miner's inches in CO

One cubic foot per second (cfs) is a volume of water 1 foot wide, 1 foot long, and 1 foot high passing a given point every second.

One acre-inch is a volume that would cover 1 acre of land

1 inch deep. One acre-foot would cover 1 acre 1 foot deep.

One acre inch per 24-hour day takes 18.7 gpm continuous flow.

A flow of 1 cfs for 1 hour = 0.99 acre-inch.

Continuous flow of 1 gpm per acre = 0.053 inches per 24-hour day.

$$\text{gpm} = \text{cfs} \times 448.8 \qquad \text{cfs} = \text{gpm} \times 0.00223$$

$$\text{Gross application of water} = \frac{\text{gpm} \times \text{hours}}{450 \times \text{number of acres}}$$

(in acre inches per acre)

Liters	Gallons	Cubic Feet	Cubic Meters	Acre Inches	Acre Feet
1	0.2642	0.0353			
3.785	1	0.1337	0.003785		
28.32	7.48	1	0.02832		
1000	264.2	35.314	1		
	27,154	3,630		1	0.0833
	325,850	43,560	1233.5	12	1
	1 million				3.07

## Weight Conversions

---

1 kilogram = 2.20 pounds = 1,000 grams

1 gram = 28.4 ounces

1 pound = 7,000 grains

1 gallon water = 8.33 pounds

1 cubic foot water = 62.4 pounds

## Length Conversions

Inches	Links	Feet	Yards	Meters	Rods/ Poles	Chains	Kilo- meters	Miles
7.92	1							
12		1		0.3048				
36		3	1	0.9144				
39.37		3.28		1			0.001	0.000622
	25	16.5	5.5		1			
	100	66	22		4	1		
			1093.61	1000			1	0.62137
		5280	1760	1609	320	80	1.61	1

## Area Conversions

Square Meters	Acres	Hectares	Square Feet	Square Yards	Square Rods	Square Chains
1	0.000247	.0001	10.76	1.196		
4049	1	0.405	43,560	4,840	160	10
10,000	2.471	1	107,639	11,960		

$$\text{Square feet} \times 0.000023 = \text{acres}$$

$$\text{Square yards} \times 0.00021 = \text{acres}$$

$$\text{Square rods} \times 0.0062 = \text{acres}$$

$$\text{Square chains} \times 0.10 = \text{acres}$$

$$\text{Triangle area} = \frac{1}{2} \text{ base} \times \text{height}$$

$$\text{Rectangle area} = \text{length} \times \text{width}$$

$$\text{Circle area} = \pi \times \text{radius}^2 \text{ or } 3.1416 \times \text{radius}^2$$

$$\text{Circle circumference} = \pi \times \text{diameter} \text{ or } 3.1416 \times \text{diameter}$$

## Temperature Conversions

$$^{\circ}\text{F} = (1.8 \times ^{\circ}\text{C}) + 32$$

$$^{\circ}\text{C} = \frac{(^{\circ}\text{F} - 32)}{1.8}$$

## Power Conversions

Kilowatt	Horsepower	BTU/hour
1	1.341	3,413
0.746	1	2,545

## Electrical Formulas

### Single Phase Power Supply

$$\text{Electric Demand} = \text{kW} = \frac{V \times I}{1000}$$

$$\begin{aligned}\text{Electric Consumption or Energy} &= \text{kWh} = \text{kW} \times \text{hours} \\ &= \frac{V \times I \times \text{hours}}{1000}\end{aligned}$$

Where V = voltage I = current (amps) kW = kilowatts

### Three Phase Power Supply

$$\text{Electric Demand} = \text{kW} = \frac{V \times I \times 1.73}{1000}$$

$$\begin{aligned}\text{Electric Consumption or Energy} &= \text{kWh} = \text{kW} \times \text{hours} \\ &= \frac{V \times I \times 1.73 \times \text{hours}}{1000}\end{aligned}$$

Kilowatt (kW) = Electric Demand = 1000 watts

Kilowatt-hours (kWh) = Electric Consumption

$$= 1000 \text{ watts} \times \text{hours} = \text{kW} \times \text{hours}$$

To find approximate annual operating hours for an irrigation system, divide average monthly demand from your electric bills by total kWh over the whole irrigation season (found by adding together the kWh numbers in your power bills).

**Example:** Average monthly demand was 25 kW and you used a total of 27,650 kWh during the irrigation season.  
 $27,650 \text{ kWh} \div 25 \text{ kW} = 1,106 \text{ operating hours.}$

# Pressure Conversions

Pounds per Square Foot	Inches of Head	Kilo-Pascals	Feet of Head	Inches of Mercury	Pounds per Square Inch	Atmospheres
1	0.1926	0.0479	0.01605	0.01414	0.00695	0.000473
5.1972	1	0.249	0.08333	0.07343	0.0361	0.002454
20.886	4.022	1	0.331	0.296	0.143	0.0099
62.32	12	3.024	1	0.88	0.4335	0.0295
70.7262	13.6185	3.3864	1.1349	1	0.491	0.033421
144	27.73	6.985	2.31	2.03	1	0.068
2,116.22	407.5	101.32	33.93	29.92	14.7	1

## Pressure Loss: pounds per square inch (psi) lost per 100 feet of pipe

gpm	3/4-inch pipe			1-inch pipe			1.5-inch pipe			2-inch pipe			3-inch pipe			
	S	PE	P	S	PE	P	S	PE	P	S	A	P	S	A	P	
2	0.83	0.45	0.39	0.26	0.14	0.12	0.03									
5	4.55	2.43	2.14	1.40	0.75	0.66	0.17	0.09	0.08	0.05	0.06	0.02				
10	8.79	7.74	5.07	2.72	2.39	2.39	0.63	0.34	0.30	0.19	0.20	0.09	0.03	0.03		
15				5.75	5.06	5.06	1.34	0.72	0.63	0.40	0.43	0.19	0.06	0.05	0.03	
20					8.63	8.63	2.28	1.22	1.07	0.68	0.72	0.32	0.10	0.09	0.05	
30							4.83	2.58	2.27	1.43	1.54	0.67	0.21	0.19	0.10	
40							8.22	4.40	3.87	2.44	2.62	1.15	0.36	0.33	0.17	
50								6.65	5.86	3.68	3.96	1.74	0.54	0.50	0.25	
60									8.21	5.16	5.54	2.43	0.76	0.70	0.36	
70										6.87	7.38	3.24	1.01	0.93	0.47	
80												4.15	1.29	1.19	0.61	

S = Steel Pipe PE = Polyethylene Pipe A = Aluminum Pipe P = Plastic Pipe

*Example:* A flow of 20 gpm through 1.5-inch polyethylene pipe is losing 1.22 psi per 100 feet of pipe.

Note: Multiply psi lost  $\times$  2.31 to get feet of head lost.

### Pressure Loss: pounds per square inch (psi) lost per 100 feet of pipe, continued

gpm	4-inch pipe		6-inch pipe		8-inch pipe		10-inch pipe		12-inch pipe			
	S	A	P	S	A	P	S	A	P	S	A	P
100	0.54	0.35	0.24	0.07	0.05	0.03						
150	1.30	0.75	0.51	0.16	0.10	0.07	0.04	0.03				
200	1.90	1.58	0.87	0.27	0.18	0.12	0.06	0.04	0.03	0.02		
300	4.10	2.75	1.85	0.57	0.40	0.26	0.14	0.09	0.06	0.05	0.03	0.02
350		3.60	2.35	0.75	0.50	0.34	0.19	0.12	0.08	0.06	0.04	0.03
400		4.65	3.20	1.00	0.65	0.44	0.24	0.16	0.11	0.08	0.05	0.04
450			4.00	1.20	0.80	0.55	0.30	0.19	0.14	0.10	0.06	0.05
500			5.00	1.50	1.00	0.67	0.36	0.24	0.17	0.12	0.08	0.06
600				2.10	1.38	0.95	0.51	0.34	0.23	0.17	0.11	0.08
												0.05
												0.03

S = Steel Pipe    A = Aluminum Pipe    P = Plastic Pipe

### Pressure Loss: pounds per square inch (psi) lost per 100 feet of pipe, continued

gpm	4-inch pipe		6-inch pipe		8-inch pipe		10-inch pipe		12-inch pipe				
	S	A	S	A	S	A	S	A	S	A			
700		1.85	2.80	1.25	0.70	0.45	0.31	0.23	0.15	0.10	0.06	0.04	
800		2.40	3.60	1.60	0.87	0.55	0.39	0.29	0.18	0.13	0.08	0.06	
900		3.00	4.40	2.00	1.10	0.72	0.50	0.36	0.24	0.17	0.10	0.07	
1000		3.60		2.45	1.33	0.87	0.61	0.45	0.28	0.21	0.19	0.12	0.08
1200		5.00		3.50	1.90	1.18	0.85	0.63	0.41	0.29	0.26	0.17	0.12
1400				4.55	2.55	1.65	1.12	0.85	0.54	0.38	0.35	0.23	0.16
1600					3.20	2.15	1.42	1.10	0.69	0.48	0.45	0.29	0.20
1800					4.00	2.65	1.79	1.34	0.90	0.60	0.56	0.36	0.25
2000					4.90	3.20	2.20	1.65	1.10	0.74	0.69	0.45	0.30

S = Steel Pipe    A = Aluminum Pipe    P = Plastic Pipe

Example: A flow of 1,400 gpm through eight-inch steel pipe is losing 2.55 psi per 100 feet of pipe.

# Water Velocity Formula

Water velocity in feet per second (fps) =  $0.409 \times$  flow in gallons per minute (gpm) divided by the pipe diameter (in inches) squared.

$$= \frac{0.409 \times \text{flow (gpm)}}{\text{pipe diameter (inches)}^2}$$

**Example:** 300 gpm through a 6-inch diameter pipe.

$$= \frac{0.409 \times 300}{6^2} = 3.4 \text{ fps}$$

## Recommended Maximum Flow Rate by Pipe Size

Pipe diameter (inches)	2	3	4	5	6	8	10	12	16
Flow rate (gpm)	50	110	200	310	440	780	1225	1760	3140

*Note:* For maximum efficiency:

- Keep water velocity in suction line < 5 fps; 2-3 fps is best.
- Keep water velocity in mainline < 7 fps; < 5 fps is best.
- Increasing pipe size, reducing the flow rate, and changing pipe type can save energy by lowering water velocity.

## Other Pumping Plant Formulas

**Total Dynamic Head (TDH) =**  
Total Lift (Suction + Discharge)  
+ Pressure Head  
+ Velocity Head  
+ Pipe Friction Loss

**Discharge Lift (feet) =** Distance in feet from centerline of pump impeller to pressure gauge.

**Suction Lift (feet) =** Distance in feet from water level on suction side of pump to centerline of pump impeller.

**Pressure Head (feet) =** Pressure in psi from a gauge at or near the pump discharge flange  $\times 2.31$  (psi  $\times 2.31$ ).

**Example:** If the gauge reads 20 psi, the pressure head =  $20 \times 2.31 = 46.2$  feet.

Velocity Head (feet) = Water velocity in feet per second squared divided by 64.35 =  $\frac{(\text{fps})^2}{64.35}$

**Note:** In most pumping systems, velocity head can be ignored.

**Pipe Friction Loss (feet):** See tables on pages 62-64. Multiply psi losses times 2.31 to get feet of head loss.

**Example:** Using water velocity found on preceding page,

$$= \frac{(3.4 \text{ fps})^2}{64.35} = 0.18 \text{ feet}$$

Water Horsepower (WHP)

$$= \frac{\text{system gallons per minute (gpm)} \times \text{TDH (in feet)}}{3,960}$$

**Example:** 300 gpm flowing through 6-inch steel pipe is losing 0.57 psi or 1.32 feet of head per 100 feet of pipe. If the system is 200 feet long, Pipe Friction Loss = 2.64 feet.

Input kW (for pumps with electric motors)

$$= \frac{3.6 \times \text{Revs} \times Kh \times PTR \times CTR}{\text{Time (seconds)}}$$

Where: *Revs* = Number of meter revolutions (usually 10)

*Kh* = Meter Constant (noted on electric meter)

*PTR* = Transformer Ratio (usually 1)

*CTR* = Transformer Ratio (usually 1)

*Time* = Number of seconds it takes for the meter to make 10 revolutions

Electric Horsepower (EHP) = Input kW  $\times$  1.34

Diesel Input Horsepower (IHP<sub>diesel</sub>)

$$= \frac{\text{gallons of Diesel used per hour}}{55}$$

$$\begin{aligned} \text{Propane Input Horsepower (IHP}_{\text{propane}}) \\ = \frac{\text{gallons of propane used per hour}}{36.15} \end{aligned}$$

$$\begin{aligned} \text{Natural Gas Input Horsepower (IHP}_{\text{natural gas}}) \\ = \frac{\text{dKt of natural gas used per hour}}{392.9} \end{aligned}$$

**Note:** 1 dKt = decatherm = 1,000,000 Btu. Contact your natural gas supplier for a conversion to decatherms, if needed.

$$\text{Overall Pumping Plant Efficiency} = \frac{\text{WHP}}{\text{EHP}} \quad \text{OR} \quad \frac{\text{WHP}}{\text{IHP}^*}$$

\*Diesel, propane or natural gas

$$\begin{aligned} \text{Brake Horsepower (BHP)} = \\ \frac{\text{motor efficiency} \times \text{EHP}}{100} \quad \text{OR} \quad \frac{\text{motor efficiency} \times \text{IHP}}{100} \end{aligned}$$

$$\text{Pump Efficiency} = \frac{\text{WHP}}{\text{BHP}}$$

$$\begin{aligned} \text{Net water application per irrigation period (inches)} = \\ \frac{\text{set time (hrs)} \times \text{flow rate (gpm)} \times 96.3 \times \text{system efficiency}}{\text{irrigated area (square feet)}} \end{aligned}$$

$$\begin{aligned} \text{Set time (hours)} = \\ \frac{\text{net water application (inches)} \times \text{irrigated area (sq ft)}}{\text{flow rate (gpm)} \times 96.3 \times \text{system efficiency}} \end{aligned}$$

For **surface irrigation systems**, a handy formula is:

$$\begin{aligned} \text{Set time (hours)} = \\ \frac{\text{gross water application (inches)} \times \text{area irrigated (acres)}}{\text{flow rate (cfs)}} \end{aligned}$$

# A Simple Method to Estimate Your Pumping Plant Efficiency

---

Pumping plant efficiency measures the amount of power produced by the pump (known as *water horsepower*) per unit of input power (known as *input horsepower*).

When the system is operating under normal, stable conditions, follow the steps below:

## Step 1. Find total dynamic head (TDH) in feet.

Read pressure from gauge \_\_\_\_\_ psi  $\times 2.31 =$  \_\_\_\_\_ feet

Add height\* if pump is above water surface + \_\_\_\_\_ feet

OR

Subtract height\* if pump is below water surface  $-$  \_\_\_\_\_ feet

To get total dynamic head (feet). \_\_\_\_\_ TDH

\*Height = distance from water surface to centerline of discharge pipe.

## Step 2. Find flow rate in gallons per minute.

If your system has a flow meter, read gallons per minute (gpm). If meter reads in cubic feet per second (cfs), multiply times 448.8 to get gpm.

\_\_\_\_\_ gpm

If your system doesn't have a flow meter, do a *bucket test*:

### 2a. Bucket test for hand move, side roll, or linear move systems:

Measure flow of one sprinkler per lateral that is on relatively level ground. The selected sprinkler should be 1/3 down the length of the lateral from the mainline. Use a hose to direct the flow into a five-gallon bucket. Using a stopwatch, measure time in seconds to fill the bucket. For greater accuracy, take more than one reading per sprinkler and average the times. Repeat for other sprinklers on other laterals.

Number of seconds to fill bucket = \_\_\_\_\_ seconds

Average gpm/sprinkler = 300 divided by the number of seconds

$$300 \div \text{_____ seconds} = \text{_____ gpm}$$

Total flow per hand line or wheel line

$$= \text{Avg gpm per sprinkler} \times \text{\# of sprinklers} = \text{_____ gpm}$$

## 2b. Bucket test for pivots:

First, measure the flow of one sprinkler in each set of nozzle diameters along the pivot using the method described in 2a.

$$\begin{array}{r} \text{Seconds to} \\ \text{fill bucket} \end{array} \quad \begin{array}{r} \text{Average gpm/} \\ \text{sprinkler} \end{array} \quad \begin{array}{r} \text{No. sprinklers} \\ \text{in each set} \end{array} \quad \begin{array}{r} \text{Total gpm} \\ \text{in each set} \end{array}$$
$$300 \div \text{_____ sec} = \text{_____ gpm} \times \text{_____} = \text{_____ gpm}$$

$$300 \div \text{_____ sec} = \text{_____ gpm} \times \text{_____} = \text{_____ gpm}$$

$$300 \div \text{_____ sec} = \text{_____ gpm} \times \text{_____} = \text{_____ gpm}$$

$$\text{Total Flow} = \text{_____ gpm}$$

Next, estimate flow from end gun using end gun pressure and nozzle diameter from table below. = \_\_\_\_\_ gpm

Estimated end gun flow in gpm  
Diameter of end gun nozzle (inches)

PSI	1/2	3/4	1	1 1/2	2
10	23.6	53.2	94.4	212	378
20	33.4	75.3	134	300	534
30	40.9	92.2	164	368	654
40	47.2	106	189	425	755
50	52.8	119	211	485	845

Now add sprinkler flow to end gun flow to find total pivot flow.

$$= \text{_____ gpm}$$

## Step 3. Find water horsepower (WHP) from Steps 1 and 2.

$$\text{_____ (TDH)} \times \text{_____ (gpm)} \div 3,960 = \text{_____ WHP}$$

#### Step 4. Find input horsepower (IHP).

4a. For electric motors, locate the meter constant on the electric meter faceplate: marked Kh and followed by a number such as 57.6 or 43.2. Using a stopwatch, time the number of seconds it takes for the disk in the meter to make 10 revolutions or for the little bar to move across the screen 10 times. If your meter shows kilowatt demand, simply multiply this number times 1.34 to get input horsepower.

$$48.1 \times \text{_____ (Kh)} \div \text{_____ (secs)} = \text{_____ IHP}$$
$$\text{_____ (KW)} \times 1.34 = \text{_____ IHP}$$

4b. For diesel engines, divide gallons of fuel used per hour by 55 to get input horsepower. (Divide gallons per hour by 36.2 for propane or decatherms natural gas per hour by 392.9.)

$$\text{_____ (gallons per hour)} \div 55 = \text{_____ IHP}$$

Step 5. Determine pumping plant efficiency, using results from steps 3 and 4.

$$\text{_____ (WHP)} \div \text{_____ (IHP)} = \text{_____ \% Efficiency}$$

Step 6. Compare your efficiency to expected values below.

Rated Motor Size (HP)	Expected Efficiency (%)
3 to 5	66 %
7.5 to 10	68 %
15 to 30	69 %
40 to 60	72 %
75 +	75 %

**Note:** Efficiencies are for older pumps in excellent condition. New pumps and pumps used under mild conditions or improved design will have higher efficiencies.

Any system with pumping plant efficiency less than 65% has room for improvement. A result in the 50% range or lower indicates a significant problem requiring attention.

Note that unless hours of operation are reduced, improving pumping plant efficiency may simply increase flow rates without reducing energy consumption.