



# Anaerobic Digestion of Animal Wastes: Factors to Consider

A Publication of ATTRA - National Sustainable Agriculture Information Service • 1-800-346-9140 • www.attra.ncat.org

By John Balsam  
NCAT Energy  
Specialist  
Updated by  
Dave Ryan  
NCAT Energy  
Specialist  
©2006 NCAT

## Contents

Introduction.....	1
Digestion Process.....	2
Bio-Gas: A Resource Requiring Care .....	4
Energy Content and Relative Value of Bio-Gas.....	4
Uses of Bio-Gas .....	5
Refining Bio-Gas into Biomethane.....	6
Risks Associated with Bio-Gas.....	6
Digester Design Factors.....	6
System Costs.....	8
Summary .....	9
Assessment Resources .....	9
References .....	10
Further Resources .....	10

Anaerobic digestion is an alternative solution to livestock waste management that offers economic and environmental benefits. This publication provides an introduction to the technology of bio-gas, digester design considerations, and system costs with discussion of the digestion process, production, uses, and risks. Useful tables and further resources are included.



Turkeys. Photo by Jeff Vanuga.



Sow with piglet. Photo by Scott Bauer.



Cows and calves. Photo by Lynn Betts.  
All photos this page courtesy of USDA/ARS.

## Introduction

Rising energy prices, broader regulatory requirements, and increased competition in the marketplace are causing many in American agriculture's livestock sector to consider anaerobic digestion of animal wastes. They view the technology as a way to cut costs, address environmental concerns, and sometimes generate new revenues.

While hundreds of anaerobic-digestion systems have been installed in Europe and the U.S. since the 1970s, it was not until the 1990s that better designed, more successful projects started to come on line in the U.S. Today, an estimated 97 farm-scale projects are in operation, in start-up, or under construction on swine, dairy, and poultry farms across the country. (1)

Key by-products of anaerobic digestion include digested solids and liquids, which may be used as soil amendments or liquid fertilizers. Methane, the primary component of "bio-gas," can be used to fuel a variety of cooking, heating, cooling, and lighting applications, as well as to generate electricity. Capturing and using the methane also precludes its release to the atmosphere, where it has twenty-one times more global warming potential than carbon dioxide. (2)

Despite the many benefits, anaerobic digestion systems are not appropriate for all farm operations. A cooperative effort among the U.S. Departments of Agriculture, Energy and the Environmental Protection Agency to promote bio-gas projects is known as

ATTRA—National Sustainable Agriculture Information Service is managed by the National Center for Appropriate Technology (NCAT) and is funded under a grant from the United States Department of Agriculture's Rural Business-Cooperative Service. Visit the NCAT Web site ([www.ncat.org/agri.html](http://www.ncat.org/agri.html)) for more information on our sustainable agriculture projects.



AgStar. AgStar estimates that anaerobic digestion could be cost-effective on about 7,000 U.S. farms. (3) A critical issue is planning; each system needs to be designed to accommodate a variety of factors. This publication provides an overview of those factors and identifies resources for additional detailed information. Several of these resources include computational analysis tools to help users determine whether an anaerobic digestion system could be a cost-effective addition to their operation.

## Digestion Process

Anaerobic digestion works in a two-stage process to decompose organic material (i.e., volatile solids) in the absence of oxygen. Bio-gas is produced as a waste product of digestion. In the first stage, the volatile solids in manure are converted into fatty acids by anaerobic bacteria known as “acid formers.” In the second stage, these acids are further converted into bio-gas by more specialized bacteria known as “methane formers.” With proper planning and design, this anaerobic-digestion process, which has

**Figure 1. Basic components of an anaerobic-digestion system (4)**

[www.ext.colostate.edu/pubs/farmmgmt/05002.html](http://www.ext.colostate.edu/pubs/farmmgmt/05002.html)

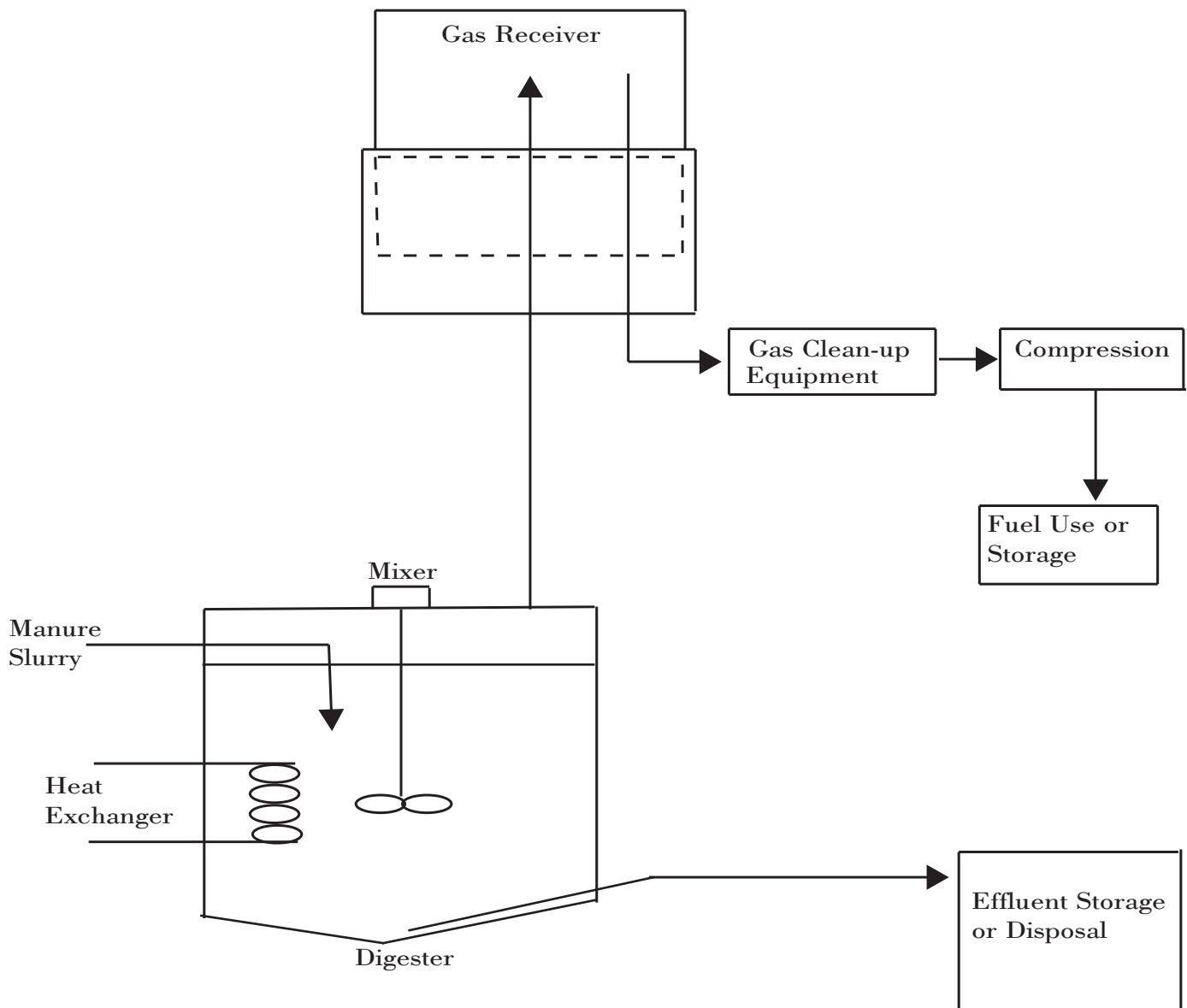

been at work in nature for millions of years, can be managed to convert a farm's wastewater into an asset.

There are several types of anaerobic digesters.

**Covered lagoons**—A pool of liquid manure topped by a pontoon or other floating cover. Seal plates extend down the sides of the pontoon into the liquid to prevent exposure of the accumulated gas to the atmosphere. Designed to use manure with two percent or less solid content, this type of digester requires high throughput in order for the bacteria to work on enough solids to produce gas. Most frequently used in warmer southern regions, where the atmospheric heat can help maintain digester temperatures, this is the least expensive of all designs to install and operate. About 18 percent of all digesters presently in use in the U.S. are covered-lagoon systems.

**Complete mix**—A silo-like tank in which the manure is heated and mixed, designed to handle manure with two to ten percent solids. This is the most expensive system to install and operate, but it's particularly appropriate for operations that wash out manure. About 28 percent of all digesters in use in the U.S. are of this type.

**Plug flow**—A cylindrical tank in which the gas and other by-products are pushed out one end by new manure being fed into the other end. This design handles 11 to 13 percent solids and typically employs hot-water piping through the tank to maintain the necessary temperature. Most appropriate for livestock operations that remove manure mechanically rather than washing it out, the plug-flow system accounts for more than half of all digesters presently in use.

**Fixed film**—A tank is filled with a plastic medium that supports a thin film of bacteria called a biofilm. This design handles one to two percent solids, and uses a shorter retention time, as short as two to six days. (5) Only about one percent of systems currently installed in the U.S. are of this type.

There are also a number of hybrid systems being designed and installed, a strong

indication that no single system is right for all or even most situations.

Starting the digestion process is not difficult, but it does require patience. The digester tank is filled with water and then heated to the desired temperature. "Seed" sludge from a municipal sewage treatment plant is then added to 20 to 25 percent of the tank's volume, followed by gradually increasing amounts of fresh manure over a six to eight-week period until the desired loading rate is reached. Assuming that the temperature within the system remains relatively constant, steady gas production should occur in the fourth week after start-up. The bacteria may require two to three months to multiply to an efficient population. (6)

There are two distinct temperature ranges most suitable for gas production, and different bacteria operate in each of these ranges. Mesophilic bacteria optimally function in the 90° to 110°F range. Thermophilic bacteria are most productive in the 120° to 140°F range. Thermophilic digestion kills more pathogenic bacteria, but it has higher costs due to maintaining higher temperatures, and thermophilic digesters may be less stable. Bacterial digestion in covered lagoons at temperatures below 90°F is called psychrophilic. Psychrophilic means a preference for lower temperatures; however, digestion slows down or stops completely below 60° or 70°F, so these digesters do not produce methane all of the time.

Temperature within the digester is critical, with maximum conversion occurring at approximately 95°F in conventional mesophilic digesters. For each 20°F decrease in temperature, gas production falls by approximately 50 percent. (7)

Even more significant is the need to keep the temperature steady. Optimal operation occurs when the methane formers use all the acids at approximately the same rate that the acid formers produce them. Variations of as little as 5°F can inhibit methane formers enough to tip the balance of the process and possibly cause system failure. (7)

**S**tarting the digestion process is not difficult, but it does require patience.

**T**he most common means of collecting and storing the gas produced by a digester is with a floating cover—a weighted pontoon that floats on the liquid surface of a collection/storage basin.

Temperature is just one of the many important factors in successfully starting and operating an anaerobic-digestion system. (7) The other key factors include:

**Loading rate.** The system’s design will dictate loading rates and contents, but experience indicates that uniform loading, on a daily basis, of manure with 6 to 10 percent solids generally works best. The load’s retention time in the digester will typically range from 15 to 30 days.

**Mixing.** The loaded manure needs to be mixed regularly to prevent settling and to maintain contact between the bacteria and the manure. The mixing action also prevents the formation of scum and facilitates release of the bio-gas.

**Nutrients.** The best digestion occurs with a carbon to nitrogen ratio between 15:1 and 30:1 (optimally 20:1). Most fresh animal manures fall within this range and require no adjustment. Nutrient imbalance can occur, however, if excessive amounts of exposed feedlot manure become part of the load. Adding crop residues or leaves (both can be heavy in carbon) can improve digester performance.

**Management.** Anaerobic digesters require regular and frequent monitoring, primarily to maintain a constant desired temperature and to ensure that the system flow is not clogged. Failure to properly manage the digester’s sensitivity to its environment can result in a significant decline in gas production and require months to correct.

**Safety.** Working with anaerobic digester bio-gas, and especially with methane (the major component of the gas), warrants extreme caution. Methane, when mixed with air, is highly explosive. In addition, because digester gas is heavier than air, it displaces oxygen near the ground, and if hydrogen sulfide is still present, the gas can act as

a deadly poison. It is critical that digester systems be designed with adequate venting to avoid these dangerous situations.

**Storage.** Because of the high pressure and low temperature required, it is impractical to liquefy methane for use as a liquid fuel. Instead, the gas can be collected and stored for a period of time until it can be used. The most common means of collecting and storing the gas produced by a digester is with a floating cover—a weighted pontoon that floats on the liquid surface of a collection/storage basin. Skirt plates on the sides of the pontoon extend down into the liquid, thereby creating a seal and preventing the gas from coming into contact with the open atmosphere. High-pressure storage is also possible, but is both more expensive and more dangerous and should be pursued only with the help of a qualified engineer.

## Bio-Gas: A Resource Requiring Care

Bio-gas produced in an anaerobic digester contains methane (60 to 70 percent), carbon dioxide (30 to 40 percent), and various toxic gases, including hydrogen sulfide, ammonia, and sulfur-derived mercaptans. Bio-gas also typically contains 1 to 2 percent water vapor.

## Energy Content and Relative Value of Bio-Gas

At roughly 60 percent methane, bio-gas possesses an energy content of 600 Btu/ft<sup>3</sup>. For comparison, **Table 1** presents the energy content of several other well-known energy sources.

**Table 1: Energy Content of Common Fuels**

<b>Propane</b>	92,000 Btu/gal	<b>Diesel fuel</b>	138,000 Btu/gal
<b>Natural Gas</b>	1,000 Btu/ft <sup>3</sup>	<b>No. 2 fuel oil</b>	138,000 Btu/gal
<b>Electricity</b>	3,414 Btu/kWh	<b>Coal</b>	25,000,000 Btu/ton

*Source: Barker, James C. 2001. Methane Fuel Gas from Livestock Wastes: A Summary. North Carolina State University Cooperative Extension Service, Publication #EBAE 071-80.*

<b>Table 2. Energy Content of Bio-gas from Various Animals</b>				
	<b>Swine (per head)</b>	<b>Dairy (per head)</b>	<b>Beef (per head)</b>	<b>Poultry (layers) (per bird)</b>
Animal weight (lbs.)	135	1,400	800	4
<b>Expected Energy Content</b>				
Gross energy content (Btu/head/day)	2,300	27,800	16,600	180
Net energy content (Btu/head/day) (uses 35% of gross to operate digester)	1,500	18,000	10,700	110
<i>Source: Barker, James C. 2001. Methane Fuel Gas from Livestock Wastes: A Summary. North Carolina State University Cooperative Extension Service, Publication #EBAE 071-80.</i>				

Putting these energy-content values in the context of an anaerobic-digestion system means the energy production per animal can be estimated, as seen in **Table 2**.

In **Table 3**, North Carolina State University's Cooperative Extension Service has converted the energy-content figures from **Table 2** into bio-gas net returns relative to four other common energy sources.

## Uses of Bio-Gas

Because of the extreme cost and difficulty of liquefying bio-gas, it is not feasible for use as a tractor fuel. Bio-gas has many other on-farm applications, however, including virtually anywhere natural gas is used—for cooking, heating (space heating, water heating, grain drying), cooling, and lighting. In most cases, the equipment designed to burn natural gas will require certain modifications to accommodate the slightly different burn characteristics of bio-gas.

Bio-gas can also be used to fuel generators to produce steam and electricity. In some cases, the electricity can be sold to a local utility, possibly in a net metering arrangement. This option should be explored early, however, to make sure the utility is amenable to such arrangements.

North Carolina State University's Cooperative Extension Service developed several specific examples of how bio-gas can be applied on-farm:

<b>Table 3. Bio-gas Gas Net Returns from Various Animals</b>				
	<b>Swine</b>	<b>Dairy</b>	<b>Beef</b>	<b>Poultry (layers)</b>
<b>Electricity Equivalent</b>	<b>----- per head per year -----</b>			
kWh (20% combined generating efficiency)	32	385	230	2.5
Value (@ \$.085/kWh)	\$2.76	\$32.73	\$19.55	\$0.21
<b>Natural Gas Equivalent</b>				
Mcf	0.55	6.60	3.90	0.04
Value (@ \$11.04/Mcf)	\$6.07	\$72.89	\$43.07	\$0.44
<b>Propane (LP Gas) Equivalent</b>				
Gallons	6	72	43	0.45
Value (@ \$2.00/gallon)	\$12.00	\$144.00	\$86.00	\$0.90
<b>No. 2 Fuel Oil Equivalent</b>				
Gallons	4	48	28	0.3
Value (@ \$2.00/gallon)	\$8.00	\$96.00	\$56.00	\$0.60
<i>Source: Barker, James C. 2001. Methane Fuel Gas from Livestock Wastes: A Summary. North Carolina State University Cooperative Extension Service, Publication #EBAE 071-80. Updated to 2006 prices by NCAT.</i>				

1. A well-insulated, three-bedroom home that requires 900,000 Btu/day for heating in cold weather could be served by 50 dairy cattle, 600 hogs, or 7,870 layers (assuming that around 35 percent of the bio-gas produced will be used to maintain the digester's temperature).
2. A dairy using the national average of 550 kWh/cow/year could

generate 70 percent of its electrical needs with bio-gas (assuming 20 percent generator efficiency and that around 35 percent of the bio-gas produced will be used to maintain the digester's temperature).

3. A swine operation that uses about 55 kWh of electricity and 5.75 gallons of LP gas per hog per year (including feed mill and incinerator) could supply 40 percent of its energy needs with bio-gas (assuming 20 percent generator efficiency and that around 35 percent of the bio-gas produced will be used to maintain the digester's temperature).

The number of animals required for a digester system to be cost effective depends upon your situation and upon what you wish to get out of the digester. Some dairy operations with as few as 100 cows have installed cost effective digester systems for odor control that also produce digested solids. (8)

## Refining Bio-Gas into Biomethane

The bio-gas produced in the methane digester is primarily methane and carbon dioxide, with traces of hydrogen sulfide, and other gasses. Bio-gas by itself can be used as-is for heating and for cooking. However, use of raw bio-gas in heating equipment and in internal combustion engines will cause early failures because of the corrosive nature of the hydrogen sulfide and water vapor. Carbon dioxide in the bio-gas lowers the heating value of the gas. It should be noted that the bio-gas from the digestion of animal wastes does not have some of the contaminants of bio-gas from landfills or municipal waste water treatment plants and is therefore easier to clean up.

Hydrogen sulfide is corrosive and smelly. It can be removed from the bio-gas by injecting less than six percent volume of air into the bio-gas in the gas reservoir, by adding iron chloride to the digester influent stream, or by flowing the bio-gas through

wood chips impregnated with iron oxide (iron sponge) or through activated carbon. Carbon dioxide can be removed by bubbling the bio-gas through water in a vertical column packed-bed scrubber. Finally, moisture can be removed by flowing the bio-gas through a refrigerated coil. (9)

## Risks Associated with Bio-Gas

While methane is a very promising energy resource, the non-methane components of bio-gas (hydrogen sulfide, carbon dioxide, and water vapor) tend to inhibit methane production and, with the exception of the water vapor, are harmful to humans and/or the environment. For these reasons, the bio-gas produced should be properly "cleaned" using appropriate scrubbing and separation techniques.

In addition, the methane itself represents a serious danger, as it is odorless, colorless, and difficult to detect. Methane is also highly explosive if allowed to come into contact with atmospheric air at proportions of 6 to 15 percent methane. For these reasons, it is recommended that buildings be well ventilated; motors, wiring, and lights should be explosion-proof; flame arrestors should be used on gas lines; and alarms and gas-detection devices should be used.

## Digester Design Factors

Digesters are installed primarily for economic and/or environmental reasons. Digesters represent a way for the farmer to convert a waste product into an economic asset, while simultaneously solving an environmental problem. Under ideal conditions, an anaerobic-digestion system can convert a livestock operation's steady accumulation of manure into a fuel for heating or cooling a portion of the farm operation or for further conversion into electricity for sale to a utility. The solids remaining after the digestion process can be used as a soil amendment, applicable on-farm or made available for sale to other markets. Unfortunately, such ideal conditions seldom exist, in part because of faulty planning and design.

**D**igesters are installed primarily for economic and/or environmental reasons.

For anyone considering an anaerobic-digestion system, the single most important point to understand is that each farmer's situation is unique, and as such, requires careful consideration of many factors. Anaerobic-digestion systems can be quite costly to install, so the owner should fully understand the purpose of the system and its economics.

The size of the system is determined primarily by the number and type of animals served by the operation, the amount of dilution water to be added, and the

desired retention time. The most manageable of these factors is retention time; longer retention times mean more complete breakdown of the manure contents, but require a larger tank. **Table 4**, developed by North Carolina State University's Cooperative Extension Service, presents one set of recommended loading rates and dilution ratios for different animals. Other sources provide similar yet different recommendations, underscoring the importance of working with an individual experienced in designing anaerobic-digestion systems.

<b>Table 4. Energy Content of Bio-gas from Various Animals</b>				
	<b>Swine (per head)</b>	<b>Dairy (per head)</b>	<b>Beef (per head)</b>	<b>Poultry (layers) (per bird)</b>
<b>Design Criteria</b>				
Animal weight (lbs)	135	1,400	800	4
Total fresh manure & urine (gal/day)	1.35	12.5	6.1	0.032
Solids content (%)				
Before dilution	10.0	15.0	15.0	25.0
After dilution	6.7	8.0	8.0	8.0
Total waste volume after dilution (gal/day)	2	24	12	0.1
Volatile solids production (VS lbs/day)	1	12	5	0.038
Digester loading rate (lbs VS/ft <sup>3</sup> digester/day)	0	0	0	0.125
Digester volume (ft <sup>3</sup> /head)	5	47	19	0.3
Retention time (days)	20	15	13	22.5
Probable VS destruction (%)	50	35	45	60
<b>Anticipated Gas Yield</b>				
Yield (per ft <sup>3</sup> digester volume)	1	1	1	1
Yield (ft <sup>3</sup> /head/day)	4	46	28	0.29
Gross energy content (Btu/head/day)	2,300	27,800	16,600	180
Net energy content (Btu/head/day) (uses 35% of gross to operate digester)	1,500	18,000	10,700	110
<i>Source: Barker, James C. 2001. Methane Fuel Gas from Livestock Wastes: A Summary. North Carolina State University Cooperative Extension Service, Publication #EBAE 071-80.</i>				

North Carolina State’s Extension Service goes on to provide several good examples (see **Table 5**) of how digester tank sizes can be computed using the information in **Table 4**.

Digesters must be airtight and situated so that they can be heated, usually with hot-water piping running in and out of the digester tank. It may be possible to heat the water using the methane produced by the digester. The tank should also be insulated to help it retain optimal operating temperatures. Many practitioners take advantage of the soil’s insulating effect by at least partially burying the digester tank in a pit or piling the soil up against the tank’s sides.

As noted previously, regular—but not necessarily continuous—mixing of the digester’s contents is important to maximize gas production. This mixing can be performed by a mechanical mixer; by a compressor, which bubbles the collected gas back through the digester; or by a closed-circuit manure pump. (10) Purdue University’s Cooperative Extension Service suggests that the mechanical mixer works well, as long as a good air seal is maintained. Purdue Extension also provides the following formula to determine the horsepower needed to mix the digester contents:

$$\text{hp} = .185 \times \% \text{ total solids} \times \text{liquid capacity (in 000s of ft}^3\text{)}$$

As an example, a 10,000-ft<sup>3</sup> digester containing waste with 6 percent solids would require an 11.1-hp mixer (.185 x 6% x 10).

## System Costs

The cost of an anaerobic-digestion system can vary dramatically depending on its size, intended purposes, and sophistication. Covered lagoon system cost can be as low as \$25,000 for 150 animals (swine) and as high as \$1.3 million for 5,000 animals (dairy). Plug flow digesters range from \$200,000 for 100 dairy cows, to \$1.8 million for 7,000 dairy cows. (11)

These costs, of course, must be weighed against revenue streams developed with digestion’s by-products. In 1998, Mark Moser, Richard Mattocks, Stacy Gettier, PhD, and Kurt Roos—all highly regarded experts in the anaerobic-digester field—studied the economic returns of seven AgSTAR digester projects. Revenues came from electric generation, and sale of digested fiber for compost, and from reduced costs for natural gas and propane, as well as reduced bedding costs. Costs and annual revenues of four of these projects are available from the Minnesota Project. Of the remaining three projects, two were developed primarily for odor control rather than financial payback, and the third

**Table 5. Configuring Digester Tank Size**

<b>Example 1: 100 cow dairy herd</b>	
Fresh manure @ 15% solids	1,250 gal/day
Milk center wash water	500 gal/day
Dilution water required for 8% solids	600 gal/day
Total waste volume generated	2,350 gal/day
Digester retention time	15 days
Tank capacity (15 x 2,350)	32,250 gal
<b>Suggestion: Round tank 18 ft. diam. x 18.5 ft. tall</b>	
<b>Example 2: 200 sow farrow-to-finish operation</b>	
Fresh manure @ 10% solids	2,830 gal/day
Additional water from leaking waterers, fogggers, etc.	1,415 gal/day
Total waste volume generated	4,245 gal/day
Digester retention time	20 days
Tank capacity (20 x 4,245)	84,900 gal
<b>Suggestion: Round tank 24 ft. diam. x 25 ft. tall</b>	
<b>Example 3: 50,000 bird layer operation</b>	
Fresh manure @ 25% solids	1,620 gal/day
Dilution water required for 8% solids	3,440 gal/day
Total waste volume generated	5,060 gal/day
Digester retention time	22.5 days
Tank capacity (22.5 x 5,060)	113,850 gal
<b>Suggestion: Round tank 7 ft. diam. x 26.5 ft. tall</b>	
<i>Source: Barker, James C. 2001. Methane Fuel Gas from Livestock Wastes: A Summary. North Carolina State University Cooperative Extension Service, Publication #EBAE 071-80.</i>	

experienced problems that prevented it from realizing its expected revenues. (12)

The AgSTAR Program evaluators believe anaerobic digestion can be cost-competitive relative to conventional waste-management practices (e.g., storage tanks, storage ponds, lagoons). When the bio-gas produced by the system is put to work, digesters can reportedly have payback periods of three to seven years, substantially more attractive than the sunk costs typically associated with conventional approaches. (13)

Construction Costs and Annual Benefits			
Barham Farm	Covered Lagoon	\$289,474	\$46,000 per/year
Martin Family Farm	Covered Lagoon	\$95,200	\$16,000 per/year

Other digester case studies can be found at [www.manuremanagement.cornell.edu/HTMLs/AnaerobicDigestion.htm](http://www.manuremanagement.cornell.edu/HTMLs/AnaerobicDigestion.htm)

## Summary

Anaerobic digesters are installed for various reasons—as a means to resolve environmental problems, as a means to economically re-use an otherwise wasted resource, and as a source of additional revenue. All of these factors typically play a role in an owner’s decision to install a system.



Cow and calf. Photo by Lynn Betts. Courtesy of USDA/NRCS.

If done right, however, this decision is not a simple one. It should involve careful planning and design, preferably with input from an engineering professional and/or someone well experienced with anaerobic-digestion systems. This planning process must consider a long list of factors.

### Factors to Consider

- The specific benefits to be derived
- The number and kind of animals to be served
- Where the system might be placed
- How the manure and other inputs will be collected and delivered to the system
- How the required temperatures will be maintained
- How all the risks associated with the process, some of which are substantial, will be mitigated
- How the outputs will be handled
- The amount of monitoring and management time required

**A**naerobic digesters are installed for various reasons—as a means to resolve environmental problems, as a means to economically re-use an otherwise wasted resource, and as a source of additional revenue.

## Assessment Resources

Because anaerobic digesters are expensive to install and manage, the above considerations and many others should be researched and then factored into an economic-feasibility assessment. A number of resources have been developed to guide a prospective system owner through this assessment process:

- **AgSTAR Program**, the premier U.S. resource for information and assistance relating to methane digesters.
- **Manurenet**, the leading Canadian resource that also includes projects and providers in the U.S. and other countries.
- Various sources offer self-evaluation forms to estimate the potential of a successful digester system installation. The **Cooperative Extension Service at Purdue University’s Department of Agricultural Engineering** offers a complete

evaluation with a full example of how it should be used. ([www.ces.purdue.edu/extmedia/ae/ae-105.html](http://www.ces.purdue.edu/extmedia/ae/ae-105.html)). Though somewhat dated (published in 1980), the steps in the worksheet and most of the values used should still be valid. Only some of the dollar values, such as the current price of energy, will need to be updated. Another evaluation tool can be found at Environomics. [http://waste2profits.com/Articles/self\\_screening\\_form.htm](http://waste2profits.com/Articles/self_screening_form.htm)

## References

1. AgStar Digest Winter 2006  
[www.epa.gov/agstar/pdf/2006digest.pdf](http://www.epa.gov/agstar/pdf/2006digest.pdf)
2. Environmental Protection Agency Methane Web Page [www.epa.gov/methane/](http://www.epa.gov/methane/)
3. AgStar - Market Opportunities for Biogas Recovery Systems  
[www.epa.gov/agstar/pdf/biogas%20recovery%20systems\\_screenres.pdf](http://www.epa.gov/agstar/pdf/biogas%20recovery%20systems_screenres.pdf)
4. Hansen, R.W. 2001. Methane Generation from Livestock Wastes. Publication #5.002. Colorado State University Cooperative Extension Service. Ft. Collins, CO. 6 p. [www.ext.colostate.edu/pubs/farmmgmt/05002.html](http://www.ext.colostate.edu/pubs/farmmgmt/05002.html)
5. AgStar Digest Winter 2003  
[www.epa.gov/agstar/pdf/2002digest.pdf](http://www.epa.gov/agstar/pdf/2002digest.pdf)
6. Jones, Don D., et al. 1980. Methane Digestion from Livestock Waste <http://pasture.ecn.purdue.edu/%7Eepados/swine/pubs/methane.htm>
7. Barker, James C. 2001. Methane Fuel Gas from Livestock Wastes: A Summary. Publication #EBAE 071-80. North Carolina State University Cooperative Extension Service, Raleigh, NC. 10 p.  
[www.bae.ncsu.edu/programs/extension/publicat/wqwm/ebae071\\_80.html](http://www.bae.ncsu.edu/programs/extension/publicat/wqwm/ebae071_80.html)
8. The Minnesota Project. Anaerobic Digester Systems for Mid-Sized Dairy Farms.  
[www.mnproject.org/pdf/agstar%20report%20full%20update.pdf](http://www.mnproject.org/pdf/agstar%20report%20full%20update.pdf)
9. Sustainable Conservation. Biomethane from Dairy Waste: A sourcebook for the Production and Use of Renewable Natural Gas in California.  
[www.suscon.org/news/biomethane\\_report/Chapter\\_3.pdf](http://www.suscon.org/news/biomethane_report/Chapter_3.pdf)
10. Jones, Don D., John C. Nye, and Alvin C. Dale. 1980. Methane Generation from Livestock Waste. Publication #AE-105. Purdue University Cooperative Extension Service, West Lafayette, IN. 15 p.  
<http://pasture.ecn.purdue.edu/%7Eepados/swine/pubs/methane.htm>
11. U.S. Environmental Protection Agency. Guide to Operational Systems. AgSTAR Program. 4 p.  
[www.epa.gov/agstar/pdf/2006digest.pdf](http://www.epa.gov/agstar/pdf/2006digest.pdf)
12. Moser, Mark A., Richard P. Mattocks, Dr. Stacy Gettier, and Kurt Roos. 1998. Benefits, Costs and Operating Experience at Seven New Agricultural Anaerobic Digesters. U.S. Environmental Protection Agency. 7 p.  
[www.mnproject.org/pdf/costbenefits.pdf](http://www.mnproject.org/pdf/costbenefits.pdf)
13. U.S. Environmental Protection Agency. 2002. Managing Manure with Biogas Recovery Systems: Improved Performance at Competitive Costs. 8 p.  
[www.epa.gov/agstar/pdf/manage.pdf](http://www.epa.gov/agstar/pdf/manage.pdf)

## Further Resources

### AgSTAR Program

[www.epa.gov/agstar/](http://www.epa.gov/agstar/)

### Introduction to Systems and Concepts

Contains fact sheets that introduce the types of gas recovery systems currently in use. The fact sheets describe the systems and provide brief case study snapshots of operating systems (still in development).

### AgSTAR Digest

[www.epa.gov/agstar/resources/digest.html](http://www.epa.gov/agstar/resources/digest.html)

Contains all editions of the program's annual newsletter (starting in 1998).

### Industry Directory for On-Farm Biogas Recovery Systems

[www.epa.gov/agstar/pdf/techdir.pdf](http://www.epa.gov/agstar/pdf/techdir.pdf)

(2nd ed., July 2003) Helps farm owners and others interested in on-farm biogas recovery systems identify appropriate consultants, project developers, energy services, equipment manufacturers and distributors, and commodity organizations. It provides company descriptions and contact information for each listed business.

### AgSTAR Press

[www.epa.gov/agstar/resources/press.html](http://www.epa.gov/agstar/resources/press.html)

Contains news and media articles on digester systems from *BioCycle*, *Agri News*, and other resources.

### *AgSTAR Handbook and Software*

[www.epa.gov/agstar/resources/handbook.html](http://www.epa.gov/agstar/resources/handbook.html)

A comprehensive manual (8 chapters; 8 appendices; glossary) developed to provide guidance on developing biogas technology for commercial farms. The Handbook also contains FarmWare, an expert decision support software package that can be used to conduct pre-feasibility assessments.

### *USDA-NRCS Biogas Interim Standards*

[www.epa.gov/agstar/resources/standards.html](http://www.epa.gov/agstar/resources/standards.html)

Available in Appendix F of the Handbook.

### *Technical and Environmental Articles*

[www.epa.gov/agstar/resources.html](http://www.epa.gov/agstar/resources.html)

Contains an array of technical, economic, and science-based publications, including an excellent article titled Benefits, Costs and Operating Experience at Seven New Agricultural Anaerobic Digesters.

### *Final Report: Haubenschild Farms Anaerobic Digester*

[www.mnproject.org/pdf/](http://www.mnproject.org/pdf/)

[Haubyrptupdated.pdf](#)

The Minnesota Project's final report for the Haubenschild Dairy manure-to-methane digester.

### *Managing Manure with Biogas Recovery Systems: Improved Performance at Competitive Costs*

[www.epa.gov/agstar/pdf/manage.pdf](http://www.epa.gov/agstar/pdf/manage.pdf)

Provides background information about anaerobic digestion and explains how the methane produced from this process can be captured and used to generate heat, hot water, and electricity. Also includes information for dairy and swine farmers to help them determine if a biogas-recovery system is right for their farm. Describes the environmental benefits of anaerobic-digestion systems and provides a table that compares the cost and environmental effectiveness of conventional animal-waste systems to anaerobic-digester systems.

### **Minnesota Project**

[www.mnproject.org](http://www.mnproject.org)

The Minnesota Project is a nonprofit organization dedicated to environmental protection and sustainable development in greater Minnesota.

### **Manurenet**

<http://agrienvarchive.ca/bioenergy/manurenet.html>

### *Selecting a Digester System*

[http://agrienvarchive.ca/bioenergy/man\\_digesters\\_back.html#Selecting](http://agrienvarchive.ca/bioenergy/man_digesters_back.html#Selecting)

Access to six articles addressing the details involved in selecting a methane-digester system.

### *Cogeneration Power Sources*

[http://agrienvarchive.ca/bioenergy/man\\_digesters.html#Co-Generation](http://agrienvarchive.ca/bioenergy/man_digesters.html#Co-Generation)

Access to 11 articles discussing engines and other technologies used with a methane-digester system to generate power.

### *European, Canadian, and U.S. Digester Programs, Projects, and Providers/Consultants*

[http://agrienvarchive.ca/bioenergy/man\\_digesters.html#European](http://agrienvarchive.ca/bioenergy/man_digesters.html#European)

[http://agrienvarchive.ca/bioenergy/man\\_digesters.html#Inventory\\_of\\_Canadian](http://agrienvarchive.ca/bioenergy/man_digesters.html#Inventory_of_Canadian)

[http://agrienvarchive.ca/bioenergy/man\\_digesters.html#U.S.A.\\_Digester\\_Programs](http://agrienvarchive.ca/bioenergy/man_digesters.html#U.S.A._Digester_Programs)

Numerous instructional articles, case studies, and reports detailing the development and operation of methane-digester systems for various animals on different levels throughout the world.

### Agricultural Utilization Research Institute

[www.auri.org/research/digester/digester.htm](http://www.auri.org/research/digester/digester.htm)

(AURI) site that helps evaluate the benefits of an on-farm digester. Also has a checklist to use to determine if a digester is a viable option.

### *BioCycle Magazine*

[www.biocycle.net/](http://www.biocycle.net/)

### Energy Efficiency and Renewable Energy, U.S.

Department of Energy. 2002. *Methane (Biogas) from Anaerobic Digesters*. Consumer Energy Information: EREC Reference Briefs. Merrifield, VA. 5 p.

### Cooperative Extension Service. 2001. *Anaerobic*

*Digesters and Methane Production Questions that need to be asked and answered before investing your money*. Publication #A3766.

University of Wisconsin, Discovery Farms. 6 p.

Lusk, P. 1998. Methane Recovery From Animal Manures: A Current Opportunities Casebook, 3rd edition. NREL/SR-25145. Prepared by Resource Development Associates, Washington, DC, under contract to the National Renewable Energy Laboratory. Golden, CO. 5 p.  
[www.nrel.gov/docs/fy99osti/25145.pdf](http://www.nrel.gov/docs/fy99osti/25145.pdf)

Fulhage, Charles, Dennis Sievers, and James R. Fischer. 1993. *Generating Methane Gas From Manure*. University of Missouri Cooperative Extension Service, Columbia, MO. 8 p.  
<http://muextension.missouri.edu/explore/agguides/agengin/g01881.htm>

Mazza, Patrick. 2002. Biogas. Climate Solutions Special Report. Olympia, WA. 4 p.  
[www.climatesolutions.org/pubs/pdfs/biogas.pdf](http://www.climatesolutions.org/pubs/pdfs/biogas.pdf)

[www.ce.ufl.edu/activities/waste/wddins.html](http://www.ce.ufl.edu/activities/waste/wddins.html)

[http://en.wikipedia.org/wiki/Anaerobic\\_digestion](http://en.wikipedia.org/wiki/Anaerobic_digestion)

The University of Florida Civil Engineering Laboratory developed an activity course with information about how to build a small scale digester system for educational purposes:  
[www.ce.ufl.edu/activities/waste/wddndx.html](http://www.ce.ufl.edu/activities/waste/wddndx.html)

### **Anaerobic Digestion of Animal Wastes: Factors to Consider**

By John Balsam  
NCAT Energy Specialist  
Updated by Dave Ryan  
NCAT Energy Specialist  
©2006 NCAT

Paul Driscoll, Editor  
Cynthia Arnold, Production

This publication is available on the Web at:  
[www.attra.ncat.org/attra-pub/anaerobic.html](http://www.attra.ncat.org/attra-pub/anaerobic.html)  
and  
[www.attra.ncat.org/attra-pub/PDF/anaerobic.pdf](http://www.attra.ncat.org/attra-pub/PDF/anaerobic.pdf)

IP219  
Slot 218  
Version 102506